

Address: Yanshan County, Cangzhou City, Hebei Province, China
Website: flangeschina.com www.carbonsteelflanges.com
Email: flanges.yh@gmail.com
Phone: +86 13313073735 15303178205
Whats: +86 13313073735 15303178205
WeChat: +86 13313073735 15303178205

CONTENT

About us	01
ANSI B16.5 welding neck flanges Class 150 Class 300 Class 400 Class 600 Class 900 Class 1500 Class 2500	02
ANSI B16.5 Slip-On Flanges Class 150 Class 300 Class 400 Class 600 Class 900 Class 1500	10
ANSI B16.5 Blind Flanges Class 150 Class 300 Class 400 Class 600 Class 900 Class 1500 Class 2500	17
ANSI B16.5 Socket Weld Flanges Class 150 Class 300 Class 600 Class 900 Class 1500	25
ANSI B16.5 Lap Joint Flanges Class 150 Class 300 Class 400 Class 600 Class 900 Class 1500 Class 2500	31
ANSI B16.5 Threaded Flanges Class 150 Class 300 Class 400 Class 600 Class 900 Class 1500 Class 2500	39
ASME B16.47 Series A welding neck flanges Class 150 Class 300 Class 400 Class 600 Class 900	47
ASME B16.47 Series A Blind Flanges Class 150 Class 300 Class 400 Class 600 Class 900	53
ASME B16.47 Series B welding neck flanges Class 75 Class 150 Class 300 Class 400 Class 600 Class 900	59
ASME B16.47 Series B Blind Flanges Class 75 Class 150 Class 300 Class 400 Class 600 Class 900	66
Wall Thickness and Bore Charts	73
Alternate Flange Facings	75
RTJ Face Dimensions	77

Company Profile

China Hebei Yanhao Pipeline Equipment Co., Ltd. is a professional manufacturer of steel elbow flange pipe fittings. Located in the famous Chinese pipeline equipment base-Yanshan County, Cangzhou City, Hebei Province, China.

The company has 8 advanced pipe fitting production lines and 5 flange production lines. It has a complete set of intermediate frequency elbow hot pusher, reducer hot die press, three-way cold extrusion hydraulic press, forging hammer, vertical lathe, drilling machine and other process forming and machining equipment for the production of elbow flange pipe fittings, including $\Phi 1020\text{mm}$ large diameter. The annual production capacity of medium-frequency hydraulic pushing machine, $\Phi 1420\text{mm}$ large-diameter intermediate-frequency pipe bender, $\Phi 2438\text{mm}$ 4,000-ton large hot mold press is more than 80,000 tons.

The company's main products: flanges, elbows, Bend, reducers, tees, crosses, pipe caps and threads, socket series of pipeline components products. Materials include carbon steel, stainless steel and alloy steel. Implementation standards include ASME, ANSI, AWWA, DIN, JIS and large industry standards, etc. Yanhao Pipeline can provide any design of pipe flange and pipe fitting products to meet your customized needs. Custom pipe flanges and fittings that meet the most stringent designs are not a problem.

At the same time, the company is also equipped with a complete set of advanced physical and chemical testing, non-destructive testing, heat treatment, hydraulic testing and other product quality testing equipment, including direct-reading spectrometers, which provides a reliable guarantee for the production of products. Over the years, it has provided a large number of products and services for petroleum, chemical, shipbuilding, medicine, electric power, papermaking and other industries and won wide acclaim. It has successively become a designated enterprise of China National Chemical Engineering Corporation, a designated enterprise of China Classification Society, a member of the supply network of China Petrochemical Materials and Equipment Corporation, a member of the supply network of China National Petroleum Corporation, and a member of the power station accessories supply network of the State Power Corporation.

The company has always adhered to the corporate policy of "serving customers with loyalty and trustworthiness, and dedicating to the society with brands", with reputation first and integrity management. Respectively won the China Hebei Province Science and Technology Enterprise, Science and Technology Civilization Enterprise, Implementation of the Joint Integrity Convention Reliable Project Quality Integrity Unit, the 6th Consumer Trustworthy Unit of Cangzhou City, Hebei Province, China, and many other honors such as provincial-level contract-abiding credit enterprise.

We will be more sincere and dedicated to the cause of flanges and pipe fittings, and develop together with customers at home and abroad with a hundredfold sincere cooperation, and create brilliance together!

ANSI B16.5 Flanges

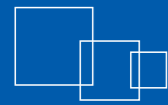

Welding Neck Flanges

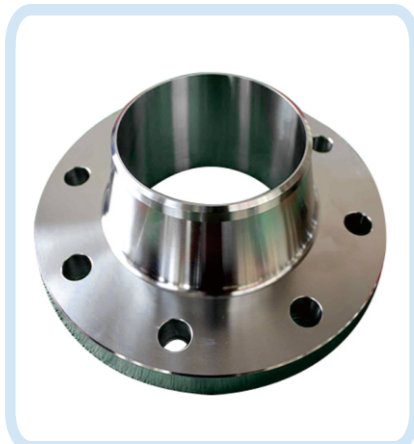
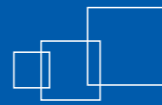

ANSI B16.5 Flanges

Class 150 Welding Neck Flanges

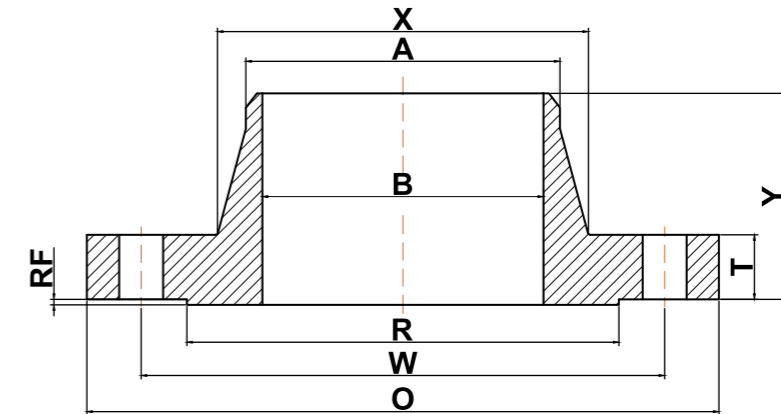

Nominal Pipe Size	Outside Diameter (O)	Bolt Circle (W)	Raised Face Diameter (R)	Number of Holes	Diameter of Holes	Bore (B)	Point of Weld (A)	Hub Diameter (X)	Thickness (T)	Length Thru Hub (Y)	Approximate Weight (lbs)
1/2	3.50	2.38	1.38	4	0.62	0.62	0.84	1.19	0.38	1.81	2
3/4	3.88	2.75	1.69	4	0.62	0.82	1.05	1.50	0.44	2.00	2
1	4.25	3.12	2.00	4	0.62	1.05	1.32	1.94	0.50	2.12	3
1 1/4	4.62	3.50	2.50	4	0.62	1.38	1.66	2.31	0.56	2.19	3
1 1/2	5.00	3.88	2.88	4	0.62	1.61	1.90	2.56	0.62	2.38	4
2	6.00	4.75	3.62	4	0.75	2.07	2.38	3.06	0.69	2.44	6
2 1/2	7.00	5.50	4.12	4	0.75	2.47	2.88	3.56	0.81	2.69	8
3	7.50	6.00	5.00	4	0.75	3.07	3.50	4.25	0.88	2.69	10
3 1/2	8.50	7.00	5.50	8	0.75	3.55	4.00	4.81	0.88	2.75	12
4	9.00	7.50	6.19	8	0.75	4.03	4.50	5.31	0.88	2.94	15
5	10.00	8.50	7.31	8	0.88	5.05	5.56	6.44	0.88	3.44	19
6	11.00	9.50	8.50	8	0.88	6.07	6.63	7.56	0.94	3.44	24
8	13.50	11.75	10.62	8	0.88	7.98	8.63	9.69	1.06	3.94	39
10	16.00	14.25	12.75	12	1.00	10.02	10.75	12.00	1.12	3.94	52
12	19.00	17.00	15.00	12	1.00	12.00	12.75	14.38	1.19	4.44	80
14	21.00	18.75	16.25	12	1.12	13.25	14.00	15.75	1.31	4.94	110
16	23.50	21.25	18.50	16	1.12	15.25	16.00	18.00	1.38	4.94	140
18	25.00	22.75	21.00	16	1.25	17.25	18.00	19.88	1.50	5.44	150
20	27.50	25.00	23.00	20	1.25	19.25	20.00	22.00	1.62	5.62	180
22	29.50	27.25	25.25	20	1.38	21.25	22.00	24.00	1.75	5.82	225
24	32.00	29.50	27.25	20	1.38	23.25	24.00	26.12	1.81	5.94	260

(a) All dimensions are in inches

(b) These flanges will be furnished with a 1/16" raised face unless otherwise specified.

(c) Standard Bore will be furnished unless otherwise specified.

ANSI B16.5 Flanges

▶ Class 300 Welding Neck Flanges

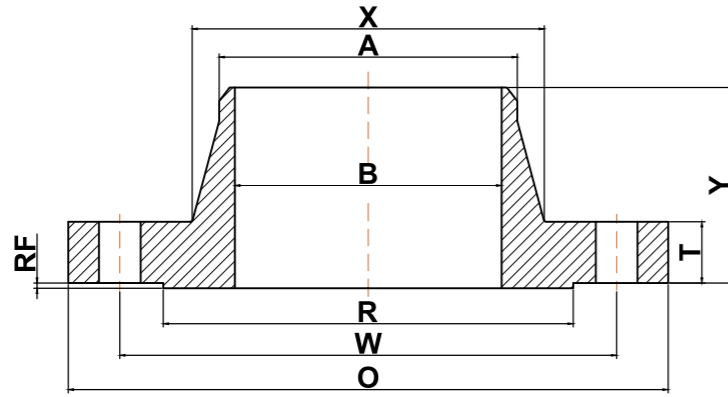

Nominal Pipe Size	Outside Diameter (O)	Bolt Circle (W)	Raised Face Diameter (R)	Number of Holes	Diameter of Holes	Bore (B)	Point of Weld (A)	Hub Diameter (X)	Thickness (T)	Length Thru Hub (Y)	Approximate Weight (lbs)
1/2	3.75	2.62	1.38	4	0.63	0.62	0.84	1.50	0.50	2.00	2
3/4	4.62	3.25	1.69	4	0.75	0.82	1.05	1.88	0.56	2.19	3
1	4.88	3.50	2.00	4	0.75	1.05	1.32	2.12	0.62	2.38	4
1 1/4	5.25	3.88	2.50	4	0.75	1.38	1.66	2.50	0.69	2.50	5
1 1/2	6.12	4.50	2.88	4	0.88	1.61	1.90	2.75	0.75	2.63	7
2	6.50	5.00	3.62	8	0.75	2.07	2.38	3.31	0.81	2.69	9
2 1/2	7.50	5.88	4.12	8	0.88	2.47	2.88	3.94	0.94	2.94	12
3	8.25	6.62	5.00	8	0.88	3.07	3.50	4.62	1.06	3.06	15
3 1/2	9.00	7.25	5.50	8	0.88	3.55	4.00	5.25	1.12	3.13	18
4	10.00	7.88	6.19	8	0.88	4.03	4.50	5.75	1.19	3.32	25
5	11.00	9.25	7.31	8	0.88	5.05	5.56	7.00	1.31	3.82	32
6	12.50	10.62	8.50	12	0.88	6.07	6.63	8.12	1.38	3.82	42
8	15.00	13.00	10.62	12	1.00	7.98	8.63	10.25	1.56	4.32	67
10	17.50	15.25	12.75	16	1.12	10.02	10.75	12.62	1.81	4.56	91
12	20.50	17.75	15.00	16	1.25	12.00	12.75	14.75	1.94	5.06	140
14	23.00	20.25	16.25	20	1.25	13.25	14.00	16.75	2.06	5.56	180
16	25.50	22.50	18.50	20	1.38	15.25	16.00	19.00	2.19	5.65	250
18	28.00	24.75	21.00	24	1.38	17.25	18.00	21.00	2.31	6.19	320
20	30.50	27.00	23.00	24	1.38	19.25	20.00	23.12	2.44	6.32	400
22	33.00	29.25	25.25	24	1.63	21.25	22.00	25.25	2.56	6.44	465
24	36.00	32.00	27.25	24	1.63	23.25	24.00	27.62	2.69	6.56	580

(a) All dimensions are in inches

(b) These flanges will be furnished with a 1/16" raised face unless otherwise specified.

(c) Standard Bore will be furnished unless otherwise specified.

ANSI B16.5 Flanges

▶ Class 400 Welding Neck Flanges

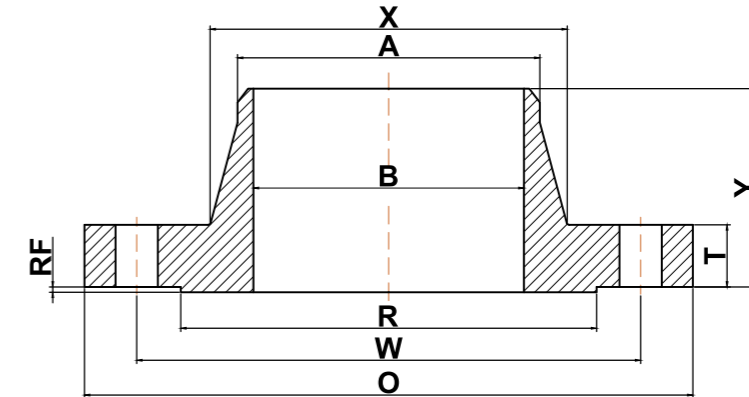

Nominal Pipe Size	Outside Diameter (O)	Bolt Circle (W)	Raised Face Diameter (R)	Number of Holes	Diameter of Holes	Bore (B)	Point of Weld (A)	Hub Diameter (X)	Thickness (T)	Length Thru Hub (Y)	Approximate Weight (lbs)
1/2	3.75	2.62	1.38	4	0.63	Specified by purchaser	0.84	1.50	0.56	2.06	2
3/4	4.62	3.25	1.69	4	0.75	Specified by purchaser	1.05	1.88	0.62	2.25	4
1	4.88	3.50	2.00	4	0.75	Specified by purchaser	1.32	2.12	0.69	2.44	4
1 1/4	5.25	3.88	2.50	4	0.75	Specified by purchaser	1.66	2.50	0.81	2.63	6
1 1/2	6.12	4.50	2.88	4	0.88	Specified by purchaser	1.90	2.75	0.88	2.75	8
2	6.50	5.00	3.62	8	0.75	Specified by purchaser	2.38	3.31	1.00	2.88	12
2 1/2	7.50	5.88	4.12	8	0.88	Specified by purchaser	2.88	3.94	1.12	3.12	18
3	8.25	6.62	5.00	8	0.88	Specified by purchaser	3.50	4.62	1.25	3.25	23
3 1/2	9.00	7.25	5.50	8	1.00	Specified by purchaser	4.00	5.25	1.38	3.38	26
4	10.00	7.88	6.19	8	1.00	Specified by purchaser	4.50	5.75	1.38	3.50	35
5	11.00	9.25	7.31	8	1.00	Specified by purchaser	5.56	7.00	1.50	4.00	43
6	12.50	10.62	8.50	12	1.00	Specified by purchaser	6.63	8.12	1.62	4.06	57
8	15.00	13.00	10.62	12	1.13	Specified by purchaser	8.63	10.25	1.88	4.62	89
10	17.50	15.25	12.75	16	1.25	Specified by purchaser	10.75	12.62	2.12	4.88	125
12	20.50	17.75	15.00	16	1.38	Specified by purchaser	12.75	14.75	2.25	5.38	175
14	23.00	20.25	16.25	20	1.38	Specified by purchaser	14.00	16.75	2.38	5.88	230
16	25.50	22.50	18.50	20	1.50	Specified by purchaser	16.00	19.00	2.50	6.00	295
18	28.00	24.75	21.00	24	1.50	Specified by purchaser	18.00	21.00	2.62	6.50	350
20	30.50	27.00	23.00	24	1.63	Specified by purchaser	20.00	23.13	2.75	6.62	425
22	33.00	29.25	25.25	24	1.75	Specified by purchaser	22.00	25.25	2.88	6.75	505
24	36.00	32.00	27.25	24	1.88	Specified by purchaser	24.00	27.62	3.00	6.88	620

(a) All dimensions are in inches

(b) These flanges will be furnished with a 1/4" raised face unless otherwise specified.

ANSI B16.5 Flanges

▶ Class 600 Welding Neck Flanges

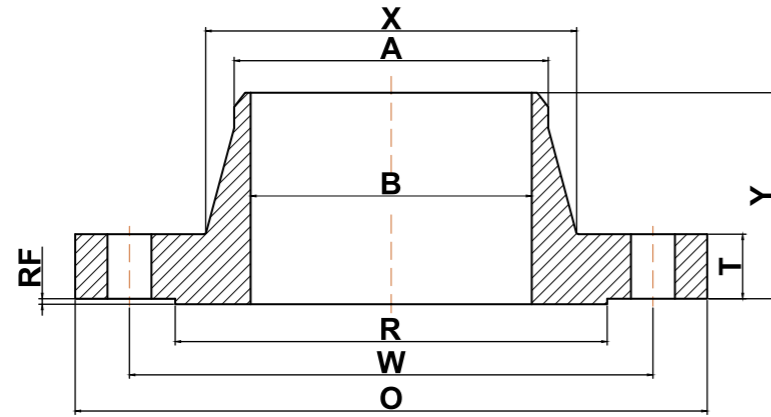

Nominal Pipe Size	Outside Diameter (O)	Bolt Circle (W)	Raised Face Diameter (R)	Number of Holes	Diameter of Holes	Bore (B)	Point of Weld (A)	Hub Diameter (X)	Thickness (T)	Length Thru Hub (Y)	Approximate Weight (lbs)
1/2	3.75	2.62	1.38	4	0.63	Specified by purchaser	0.84	1.50	0.56	2.06	2
3/4	4.62	3.25	1.69	4	0.75	Specified by purchaser	1.05	1.88	0.62	2.25	4
1	4.88	3.50	2.00	4	0.75	Specified by purchaser	1.32	2.12	0.69	2.44	4
1 1/4	5.25	3.88	2.50	4	0.75	Specified by purchaser	1.66	2.50	0.81	2.62	6
1 1/2	6.12	4.50	2.88	4	0.88	Specified by purchaser	1.90	2.75	0.88	2.75	8
2	6.50	5.00	3.62	8	0.75	Specified by purchaser	2.38	3.31	1.00	2.88	12
2 1/2	7.50	5.88	4.12	8	0.88	Specified by purchaser	2.88	3.94	1.12	3.12	18
3	8.25	6.62	5.00	8	0.88	Specified by purchaser	3.50	4.62	1.25	3.25	23
3 1/2	9.00	7.25	5.50	8	1.00	Specified by purchaser	4.00	5.25	1.38	3.38	26
4	10.75	8.50	6.19	8	1.00	Specified by purchaser	4.50	6.00	1.50	4.00	42
5	13.00	10.50	7.31	8	1.13	Specified by purchaser	5.56	7.44	1.75	4.50	68
6	14.00	11.50	8.50	12	1.13	Specified by purchaser	6.63	8.75	1.88	4.62	81
8	16.50	13.75	10.62	12	1.25	Specified by purchaser	8.63	10.75	2.19	5.25	120
10	20.00	17.00	12.75	16	1.38	Specified by purchaser	10.75	13.50	2.50	6.00	190
12	22.00	19.25	15.00	20	1.38	Specified by purchaser	12.75	15.75	2.62	6.12	225
14	23.75	20.75	16.25	20	1.50	Specified by purchaser	14.00	17.00	2.75	6.50	280
16	27.00	23.75	18.50	20	1.63	Specified by purchaser	16.00	19.50	3.00	7.00	390
18	29.25	25.75	21.00	20	1.75	Specified by purchaser	18.00	21.50	3.25	7.25	475
20	32.00	28.50	23.00	24	1.75	Specified by purchaser	20.00	24.00	3.50	7.50	590
22	34.25	30.62	25.25	24	1.88	Specified by purchaser	22.00	26.25	3.75	7.75	720
24	37.00	33.00	27.25	24	2.00	Specified by purchaser	24.00	28.25	4.00	8.00	830

(a) All dimensions are in inches

(b) These flanges will be furnished with a 1/4" raised face unless otherwise specified.

ANSI B16.5 Flanges

▶ Class 900 Welding Neck Flanges

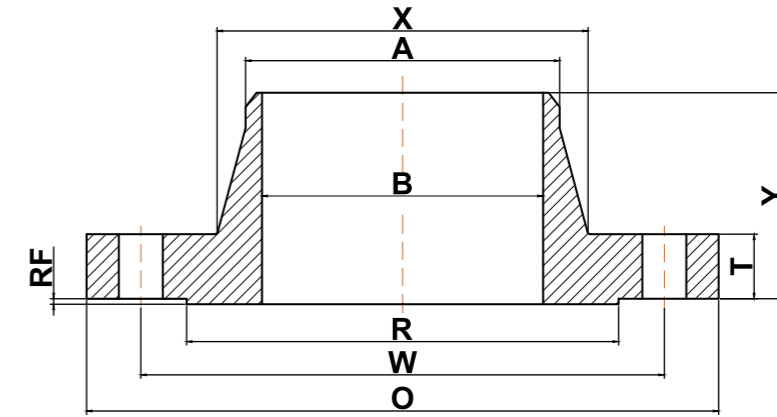

Nominal Pipe Size	Outside Diameter (O)	Bolt Circle (W)	Raised Face Diameter (R)	Number of Holes	Diameter of Holes	Bore (B)	Point of Weld (A)	Hub Diameter (X)	Thickness (T)	Length Thru Hub (Y)	Approximate Weight (lbs)
1/2	4.75	3.25	1.38	4	0.88	Specified by purchaser	0.84	1.50	0.88	2.38	5
3/4	5.12	3.50	1.69	4	0.88	Specified by purchaser	1.05	1.75	1.00	2.75	6
1	5.88	4.00	2.00	4	1.00	Specified by purchaser	1.32	2.06	1.12	2.88	9
1 1/4	6.25	4.38	2.50	4	1.00	Specified by purchaser	1.66	2.50	1.12	2.88	10
1 1/2	7.00	4.88	2.88	4	1.13	Specified by purchaser	1.90	2.75	1.25	3.25	13
2	8.50	6.50	3.62	8	1.00	Specified by purchaser	2.38	4.12	1.50	4.00	25
2 1/2	9.62	7.50	4.12	8	1.13	Specified by purchaser	2.88	4.88	1.62	4.12	36
3	9.50	7.50	5.00	8	1.00	Specified by purchaser	3.50	5.00	1.50	4.00	31
4	11.50	9.25	6.19	8	1.25	Specified by purchaser	4.50	6.25	1.75	4.50	53
5	13.75	11.00	7.31	8	1.38	Specified by purchaser	5.56	7.50	2.00	5.00	86
6	15.00	12.50	8.50	12	1.25	Specified by purchaser	6.63	9.25	2.19	5.50	110
8	18.50	15.50	10.62	12	1.50	Specified by purchaser	8.63	11.75	2.50	6.38	175
10	21.50	18.50	12.75	16	1.50	Specified by purchaser	10.75	14.50	2.75	7.25	260
12	24.00	21.00	15.00	20	1.50	Specified by purchaser	12.75	16.50	3.12	7.88	325
14	25.25	22.00	16.25	20	1.63	Specified by purchaser	14.00	17.75	3.38	8.38	400
16	27.75	24.25	18.50	20	1.75	Specified by purchaser	16.00	20.00	3.50	8.50	495
18	31.00	27.00	21.00	20	2.00	Specified by purchaser	18.00	22.25	4.00	9.00	680
20	33.75	29.50	23.00	20	2.13	Specified by purchaser	20.00	24.50	4.25	9.75	830
24	41.00	35.50	27.25	20	2.63	Specified by purchaser	24.00	29.50	5.50	11.50	1500

(a) All dimensions are in inches

(b) These flanges will be furnished with a 1/4" raised face unless otherwise specified.

ANSI B16.5 Flanges

▶ Class 1500 Welding Neck Flanges

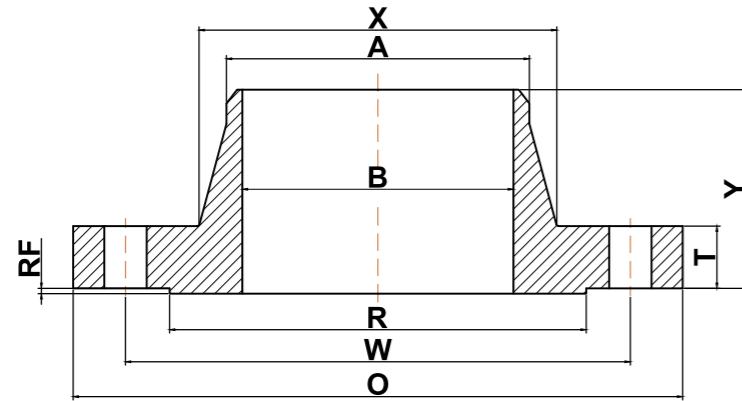

Nominal Pipe Size	Outside Diameter (O)	Bolt Circle (W)	Raised Face Diameter (R)	Number of Holes	Diameter of Holes	Bore (B)	Point of Weld (A)	Hub Diameter (X)	Thickness (T)	Length Thru Hub (Y)	Approximate Weight (lbs)
1/2	4.75	3.25	1.38	4	0.88	Specified by purchaser	0.84	1.50	0.88	2.38	5
3/4	5.12	3.50	1.69	4	0.88	Specified by purchaser	1.05	1.75	1.00	2.75	6
1	5.88	4.00	2.00	4	1.00	Specified by purchaser	1.32	2.06	1.12	2.88	9
1 1/4	6.25	4.38	2.50	4	1.00	Specified by purchaser	1.66	2.50	1.12	2.88	10
1 1/2	7.00	4.88	2.88	4	1.13	Specified by purchaser	1.90	2.75	1.25	3.25	13
2	8.50	6.50	3.62	8	1.00	Specified by purchaser	2.38	4.12	1.50	4.00	25
2 1/2	9.62	7.50	4.12	8	1.13	Specified by purchaser	2.88	4.88	1.62	4.12	36
3	10.50	8.00	5.00	8	1.25	Specified by purchaser	3.50	5.25	1.88	4.62	48
4	12.25	9.50	6.19	8	1.38	Specified by purchaser	4.50	6.38	2.12	4.88	73
5	14.75	11.50	7.31	8	1.63	Specified by purchaser	5.56	7.75	2.88	6.12	130
6	15.50	12.50	8.50	12	1.50	Specified by purchaser	6.63	9.00	3.25	6.75	165
8	19.00	15.50	10.62	12	1.75	Specified by purchaser	8.63	11.50	3.62	8.38	275
10	23.00	19.00	12.75	12	2.00	Specified by purchaser	10.75	14.50	4.25	10.00	455
12	26.50	22.50	15.00	16	2.13	Specified by purchaser	12.75	17.75	4.88	11.12	690
14	29.50	25.00	16.25	16	2.38	Specified by purchaser	14.00	19.50	5.25	11.75	940
16	32.50	27.75	18.50	16	2.63	Specified by purchaser	16.00	21.75	5.75	12.25	1250
18	36.00	30.50	21.00	16	2.88	Specified by purchaser	18.00	23.50	6.38	12.88	1625
20	38.75	32.75	23.00	16	3.13	Specified by purchaser	20.00	25.25	7.00	14.00	2050
24	46.00	39.00	27.25	16	3.63	Specified by purchaser	24.00	30.00	8.00	16.00	3325

(a) All dimensions are in inches

(b) These flanges will be furnished with a 1/4" raised face unless otherwise specified.

ANSI B16.5 Flanges

▶ Class 2500 Welding Neck Flanges

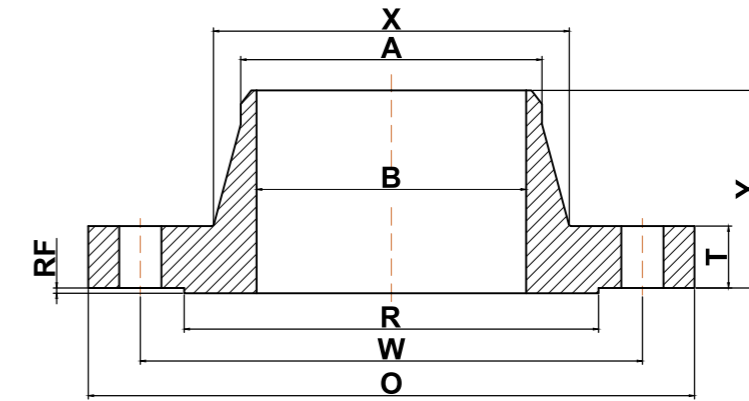

Nominal Pipe Size	Outside Diameter (O)	Bolt Circle (W)	Raised Face Diameter (R)	Number of Holes	Diameter of Holes	Bore (B)	Point of Weld (A)	Hub Diameter (X)	Thickness (T)	Length Thru Hub (Y)	Approximate Weight (lbs)
1/2	5.25	3.50	1.38	4	0.88	Specified by purchaser	0.84	1.69	1.19	2.88	7
3/4	5.50	3.75	1.69	4	0.88	Specified by purchaser	1.05	2.00	1.25	3.12	8
1	6.25	4.25	2.00	4	1.00	Specified by purchaser	1.32	2.25	1.38	3.50	12
1 1/4	7.25	5.12	2.50	4	1.13	Specified by purchaser	1.66	2.88	1.50	3.75	17
1 1/2	8.00	5.75	2.88	4	1.25	Specified by purchaser	1.90	3.12	1.75	4.38	25
2	9.25	6.75	3.62	8	1.13	Specified by purchaser	2.38	3.75	2.00	5.00	42
2 1/2	10.50	7.75	4.12	8	1.25	Specified by purchaser	2.88	4.50	2.25	5.62	52
3	12.00	9.00	5.00	8	1.38	Specified by purchaser	3.50	5.25	2.62	6.62	94
4	14.00	10.75	6.19	8	1.63	Specified by purchaser	4.50	6.50	3.00	7.50	145
5	16.50	12.75	7.31	8	1.88	Specified by purchaser	5.56	8.00	3.62	9.00	245
6	19.00	14.50	8.50	8	2.13	Specified by purchaser	6.63	9.25	4.25	10.75	380
8	21.75	17.25	10.62	12	2.13	Specified by purchaser	8.63	12.00	5.00	12.50	580
10	26.50	21.25	12.75	12	2.63	Specified by purchaser	10.75	14.75	6.50	16.50	1075
12	30.00	24.38	15.00	12	2.88	Specified by purchaser	12.75	17.38	7.25	18.25	1525

(a) All dimensions are in inches

(b) These flanges will be furnished with a 1/4" raised face unless otherwise specified.

ANSI B16.5 Flanges



Slip-On Flanges

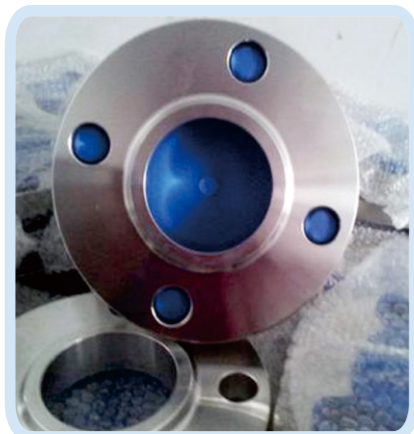

ANSI B16.5 Flanges

Class 150 Slip-On Flanges

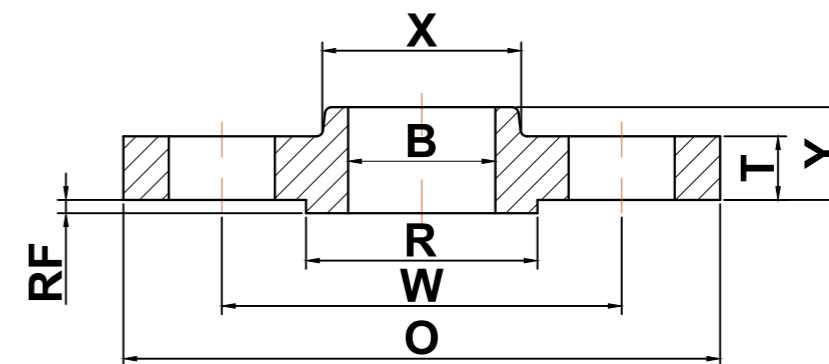

Nominal Pipe Size	Outside Diameter (O)	Bolt Circle (W)	Raised Face Diameter (R)	Number of Holes	Diameter of Holes	Bore (B)	Hub Diameter (X)	Thickness (T)	Length Thru Hub (Y)	Approximate Weight (lbs)
1/2	3.50	2.38	1.38	4	0.62	0.88	1.19	0.38	0.56	1
3/4	3.88	2.75	1.69	4	0.62	1.09	1.50	0.44	0.56	2
1	4.25	3.12	2.00	4	0.62	1.36	1.94	0.50	0.62	2
1 1/4	4.62	3.50	2.50	4	0.62	1.70	2.31	0.56	0.75	3
1 1/2	5.00	3.88	2.88	4	0.62	1.95	2.56	0.62	0.81	3
2	6.00	4.75	3.62	4	0.75	2.44	3.06	0.69	0.94	5
2 1/2	7.00	5.50	4.12	4	0.75	2.94	3.56	0.81	1.06	7
3	7.50	6.00	5.00	4	0.75	3.57	4.25	0.88	1.12	8
3 1/2	8.50	7.00	5.50	8	0.75	4.07	4.81	0.88	1.19	11
4	9.00	7.50	6.19	8	0.75	4.57	5.31	0.88	1.25	13
5	10.00	8.50	7.31	8	0.88	5.66	6.44	0.88	1.38	15
6	11.00	9.50	8.50	8	0.88	6.72	7.56	0.94	1.50	19
8	13.50	11.75	10.62	8	0.88	8.72	9.69	1.06	1.69	30
10	16.00	14.25	12.75	12	1.00	10.88	12.00	1.12	1.88	43
12	19.00	17.00	15.00	12	1.00	12.88	14.38	1.19	2.12	64
14	21.00	18.75	16.25	12	1.12	14.14	15.75	1.31	2.19	90
16	23.50	21.25	18.50	16	1.12	16.16	18.00	1.38	2.44	98
18	25.00	22.75	21.00	16	1.25	18.18	19.88	1.50	2.62	130
20	27.50	25.00	23.00	20	1.25	20.20	22.00	1.62	2.81	165
22	29.50	27.25	25.25	20	1.38	22.22	24.00	1.75	3.06	185
24	32.00	29.50	27.25	20	1.38	24.25	26.12	1.81	3.19	220

(a) All dimensions are in inches

(b) These flanges will be furnished with a 1/16" raised face unless otherwise specified.

ANSI B16.5 Flanges

▶ Class 300 Slip-On Flanges

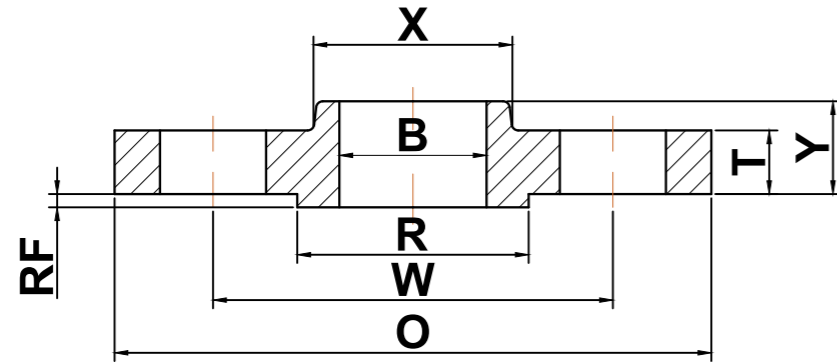

Nominal Pipe Size	Outside Diameter (O)	Bolt Circle (W)	Raised Face Diameter (R)	Number of Holes	Diameter of Holes	Bore (B)	Hub Diameter (X)	Thickness (T)	Length Thru Hub (Y)	Approximate Weight (lbs)
1/2	3.75	2.62	1.38	4	0.63	0.88	1.50	0.50	0.81	2
3/4	4.62	3.25	1.69	4	0.75	1.09	1.88	0.56	0.94	3
1	4.88	3.50	2.00	4	0.75	1.36	2.12	0.62	1.00	3
1 1/4	5.25	3.88	2.50	4	0.75	1.70	2.50	0.69	1.00	4
1 1/2	6.12	4.50	2.88	4	0.88	1.95	2.75	0.75	1.13	6
2	6.50	5.00	3.62	8	0.75	2.44	3.31	0.81	1.25	7
2 1/2	7.50	5.88	4.12	8	0.88	2.94	3.94	0.94	1.44	10
3	8.25	6.62	5.00	8	0.88	3.57	4.62	1.06	1.63	13
3 1/2	9.00	7.25	5.50	8	0.88	4.07	5.25	1.12	1.69	17
4	10.00	7.88	6.19	8	0.88	4.57	5.75	1.19	1.82	22
5	11.00	9.25	7.31	8	0.88	5.66	7.00	1.31	1.94	28
6	12.50	10.62	8.50	12	0.88	6.72	8.12	1.38	2.00	39
8	15.00	13.00	10.62	12	1.00	8.72	10.25	1.56	2.38	58
10	17.50	15.25	12.75	16	1.13	10.88	12.62	1.81	2.56	81
12	20.50	17.75	15.00	16	1.25	12.88	14.75	1.94	2.82	115
14	23.00	20.25	16.25	20	1.25	14.14	16.75	2.06	2.94	165
16	25.50	22.50	18.50	20	1.38	16.16	19.00	2.19	3.19	190
18	28.00	24.75	21.00	24	1.38	18.18	21.00	2.31	3.44	250
20	30.50	27.00	23.00	24	1.38	20.20	23.12	2.44	3.69	315
22	33.00	29.25	25.25	24	1.63	22.22	25.25	2.56	3.94	370
24	36.00	32.00	27.25	24	1.63	24.25	27.62	2.69	4.13	475

(a) All dimensions are in inches

(b) These flanges will be furnished with a 1/16" raised face unless otherwise specified.

ANSI B16.5 Flanges

▶ Class 400 Slip-On Flanges

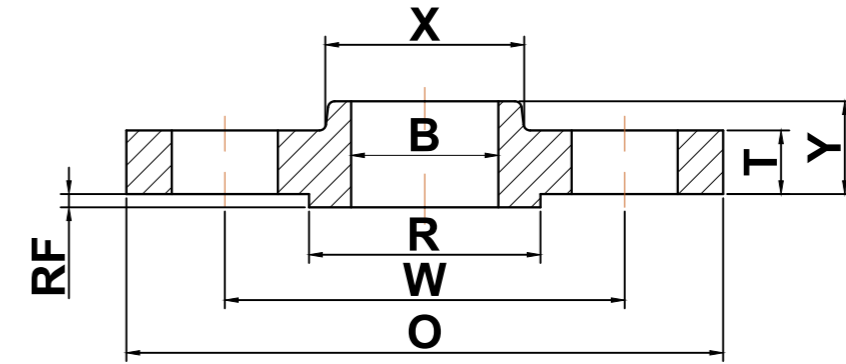

Nominal Pipe Size	Outside Diameter (O)	Bolt Circle (W)	Raised Face Diameter (R)	Number of Holes	Diameter of Holes	Bore (B)	Hub Diameter (X)	Thickness (T)	Length Thru Hub (Y)	Approximate Weight (lbs)
1/2	3.75	2.62	1.38	4	0.63	0.88	1.50	0.56	0.88	2
3/4	4.62	3.25	1.69	4	0.75	1.09	1.88	0.62	1.00	3
1	4.88	3.50	2.00	4	0.75	1.36	2.12	0.69	1.06	4
1 1/4	5.25	3.88	2.50	4	0.75	1.70	2.50	0.81	1.12	5
1 1/2	6.12	4.50	2.88	4	0.88	1.95	2.75	0.88	1.25	7
2	6.50	5.00	3.62	8	0.75	2.44	3.31	1.00	1.44	9
2 1/2	7.50	5.88	4.12	8	0.88	2.94	3.94	1.12	1.62	13
3	8.25	6.62	5.00	8	0.88	3.57	4.62	1.25	1.81	16
3 1/2	9.00	7.25	5.50	8	1.00	4.07	5.25	1.38	1.94	21
4	10.00	7.88	6.19	8	1.00	4.57	5.75	1.38	2.00	26
5	11.00	9.25	7.31	8	1.00	5.66	7.00	1.50	2.12	31
6	12.50	10.62	8.50	12	1.00	6.72	8.12	1.62	2.25	44
8	15.00	13.00	10.62	12	1.13	8.72	10.25	1.88	2.69	67
10	17.50	15.25	12.75	16	1.25	10.88	12.62	2.12	2.88	91
12	20.50	17.75	15.00	16	1.38	12.88	14.75	2.25	3.12	130
14	23.00	20.25	16.25	20	1.38	14.14	16.75	2.38	3.31	180
16	25.50	22.50	18.50	20	1.50	16.16	19.00	2.50	3.69	235
18	28.00	24.75	21.00	24	1.50	18.18	21.00	2.62	3.88	285
20	30.50	27.00	23.00	24	1.63	20.20	23.13	2.75	4.00	345
22	33.00	29.25	25.25	24	1.75	22.22	25.25	2.88	4.25	405
24	36.00	32.00	27.25	24	1.88	24.25	27.62	3.00	4.50	510

(a) All dimensions are in inches

(b) These flanges will be furnished with a 1/4" raised face unless otherwise specified.

ANSI B16.5 Flanges

▶ Class 600 Slip-On Flanges

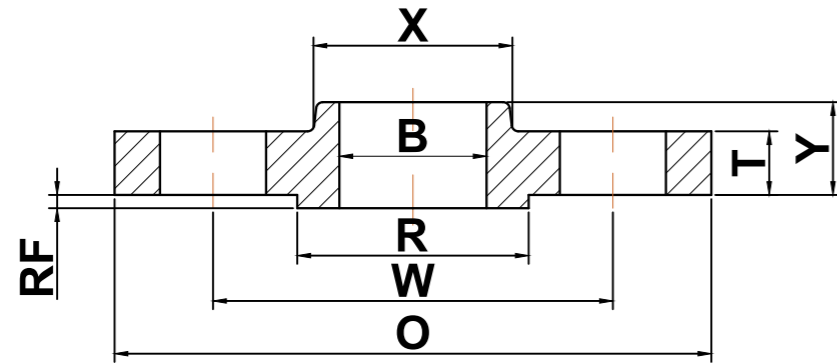

Nominal Pipe Size	Outside Diameter (O)	Bolt Circle (W)	Raised Face Diameter (R)	Number of Holes	Diameter of Holes	Bore (B)	Hub Diameter (X)	Thickness (T)	Length Thru Hub (Y)	Approximate Weight (lbs)
1/2	3.75	2.62	1.38	4	0.63	0.88	1.50	0.56	0.88	2
3/4	4.62	3.25	1.69	4	0.75	1.09	1.88	0.62	1.00	3
1	4.88	3.50	2.00	4	0.75	1.36	2.12	0.69	1.06	4
1 1/4	5.25	3.88	2.50	4	0.75	1.70	2.50	0.81	1.12	5
1 1/2	6.12	4.50	2.88	4	0.88	1.95	2.75	0.88	1.25	7
2	6.50	5.00	3.62	8	0.75	2.44	3.31	1.00	1.44	9
2 1/2	7.50	5.88	4.12	8	0.88	2.94	3.94	1.12	1.62	13
3	8.25	6.62	5.00	8	0.88	3.57	4.62	1.25	1.81	16
3 1/2	9.00	7.25	5.50	8	1.00	4.07	5.25	1.38	1.94	21
4	10.75	8.50	6.19	8	1.00	4.57	6.00	1.50	2.12	37
5	13.00	10.50	7.31	8	1.13	5.66	7.44	1.75	2.38	63
6	14.00	11.50	8.50	12	1.13	6.72	8.75	1.88	2.62	80
8	16.50	13.75	10.62	12	1.25	8.72	10.75	2.19	3.00	115
10	20.00	17.00	12.75	16	1.38	10.88	13.50	2.50	3.38	170
12	22.00	19.25	15.00	20	1.38	12.88	15.75	2.62	3.62	200
14	23.75	20.75	16.25	20	1.50	14.14	17.00	2.75	3.69	230
16	27.00	23.75	18.50	20	1.63	16.16	19.50	3.00	4.19	330
18	29.25	25.75	21.00	20	1.75	18.18	21.50	3.25	4.62	400
20	32.00	28.50	23.00	24	1.75	20.20	24.00	3.50	5.00	510
22	34.25	30.62	25.25	24	1.88	22.22	26.25	3.75	5.25	590
24	37.00	33.00	27.25	24	2.00	24.25	28.25	4.00	5.50	730

(a) All dimensions are in inches

(b) These flanges will be furnished with a 1/4" raised face unless otherwise specified.

ANSI B16.5 Flanges

▶ Class 900 Slip-On Flanges

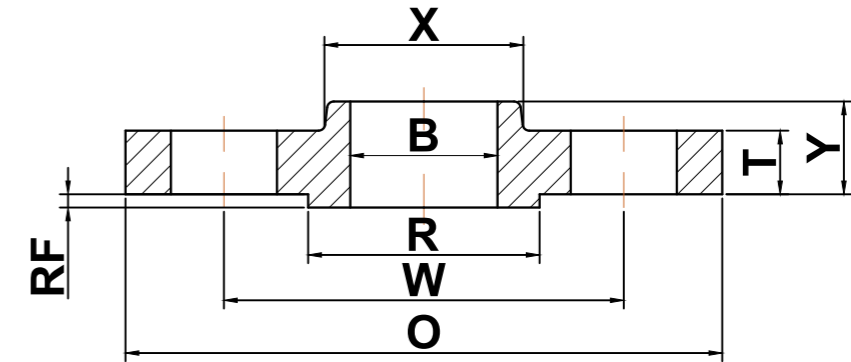

Nominal Pipe Size	Outside Diameter (O)	Bolt Circle (W)	Raised Face Diameter (R)	Number of Holes	Diameter of Holes	Bore (B)	Hub Diameter (X)	Thickness (T)	Length Thru Hub (Y)	Approximate Weight (lbs)
1/2	4.75	3.25	1.38	4	0.88	0.88	1.50	0.88	1.25	4
3/4	5.12	3.50	1.69	4	0.88	1.09	1.75	1.00	1.38	5
1	5.88	4.00	2.00	4	1.00	1.36	2.06	1.12	1.62	8
1 1/4	6.25	4.38	2.50	4	1.00	1.70	2.50	1.12	1.62	9
1 1/2	7.00	4.88	2.88	4	1.13	1.97	2.75	1.25	1.75	12
2	8.50	6.50	3.62	8	1.00	2.46	4.12	1.50	2.25	25
2 1/2	9.62	7.50	4.12	8	1.13	2.97	4.88	1.62	2.50	36
3	9.50	7.50	5.00	8	1.00	3.57	5.00	1.50	2.12	26
4	11.50	9.25	6.19	8	1.25	4.57	6.25	1.75	2.75	53
5	13.75	11.00	7.31	8	1.38	5.66	7.50	2.00	3.12	83
6	15.00	12.50	8.50	12	1.25	6.72	9.25	2.19	3.38	110
8	18.50	15.50	10.62	12	1.50	8.72	11.75	2.50	4.00	170
10	21.50	18.50	12.75	16	1.50	10.88	14.50	2.75	4.25	245
12	24.00	21.00	15.00	20	1.50	12.88	16.50	3.12	4.62	325
14	25.25	22.00	16.25	20	1.63	14.14	17.75	3.38	5.12	400
16	27.75	24.25	18.50	20	1.75	16.16	20.00	3.50	5.25	425
18	31.00	27.00	21.00	20	2.00	18.18	22.25	4.00	6.00	600
20	33.75	29.50	23.00	20	2.13	20.20	24.50	4.25	6.25	730
24	41.00	35.50	27.25	20	2.63	24.25	29.50	5.50	8.00	1400

(a) All dimensions are in inches

(b) These flanges will be furnished with a 1/4" raised face unless otherwise specified.

ANSI B16.5 Flanges

▶ Class 1500 Slip-On Flanges

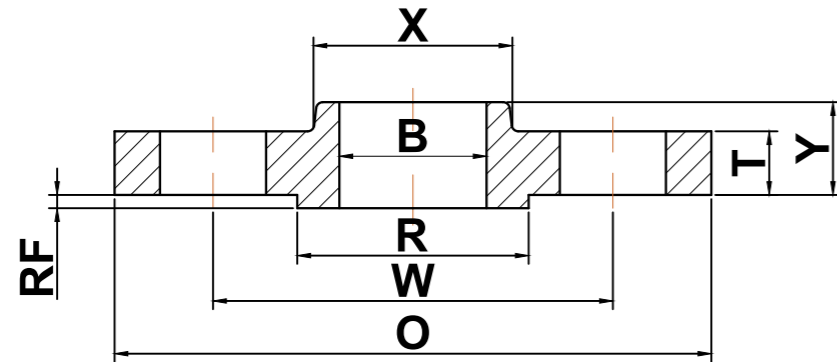

Nominal Pipe Size	Outside Diameter (O)	Bolt Circle (W)	Raised Face Diameter (R)	Number of Holes	Diameter of Holes	Bore (B)	Hub Diameter (X)	Thickness (T)	Length Thru Hub (Y)	Approximate Weight (lbs)
1/2	4.75	3.25	1.38	4	0.88	0.88	1.50	0.88	1.25	4
3/4	5.12	3.50	1.69	4	0.88	1.09	1.75	1.00	1.38	5
1	5.88	4.00	2.00	4	1.00	1.36	2.06	1.12	1.62	8
1 1/4	6.25	4.38	2.50	4	1.00	1.70	2.50	1.12	1.62	9
1 1/2	7.00	4.88	2.88	4	1.13	1.95	2.75	1.25	1.75	12
2	8.50	6.50	3.62	8	1.00	2.44	4.12	1.50	2.25	25
2 1/2	9.62	7.50	4.12	8	1.13	2.94	4.88	1.62	2.50	36

(a) All dimensions are in inches

(b) These flanges will be furnished with a 1/4" raised face unless otherwise specified.

➔ ANSI B16.5 Flanges

➔ ANSI B16.5 Flanges

▶ Class 150 Blind Flanges

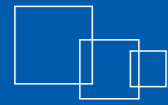

Blind Flanges

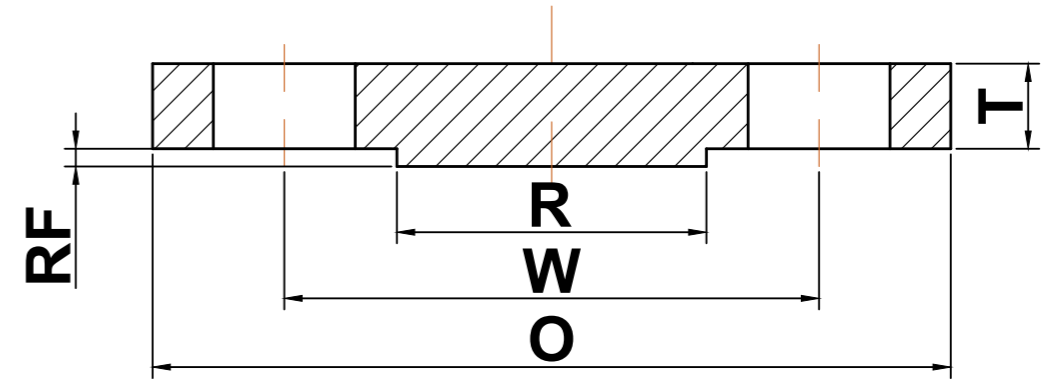
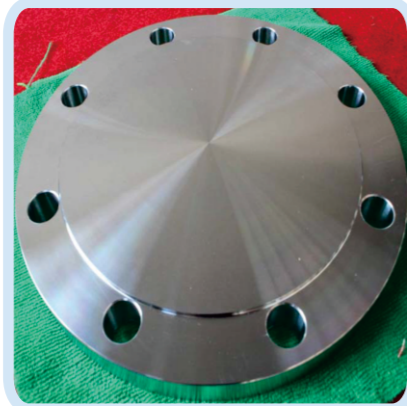
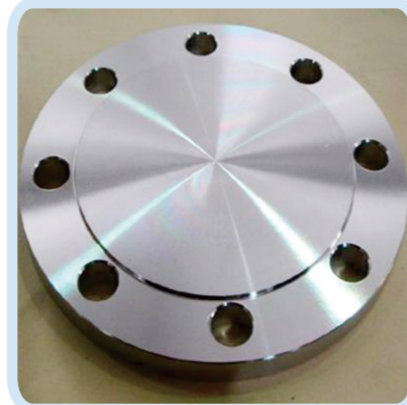
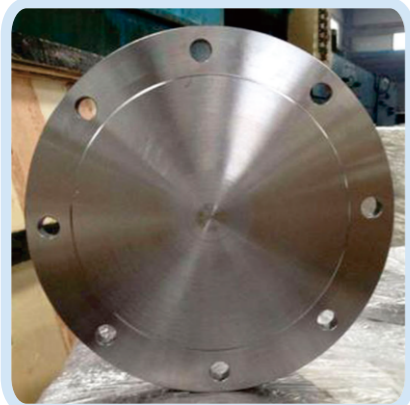
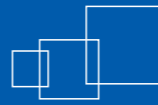

Nominal Pipe Size	Outside Diameter (O)	Bolt Circle (W)	Raised Face Diameter (R)	Number of Holes	Diameter of Holes	Thickness (T)	Approximate Weight (lbs)
1/2	3.50	2.38	1.38	4	0.62	0.38	1
3/4	3.88	2.75	1.69	4	0.62	0.44	2
1	4.25	3.12	2.00	4	0.62	0.50	2
1 1/4	4.62	3.50	2.50	4	0.62	0.56	3
1 1/2	5.00	3.88	2.88	4	0.62	0.62	4
2	6.00	4.75	3.62	4	0.75	0.69	5
2 1/2	7.00	5.50	4.12	4	0.75	0.81	7
3	7.50	6.00	5.00	4	0.75	0.88	9
3 1/2	8.50	7.00	5.50	8	0.75	0.88	13
4	9.00	7.50	6.19	8	0.75	0.88	17
5	10.00	8.50	7.31	8	0.88	0.88	20
6	11.00	9.50	8.50	8	0.88	0.94	26
8	13.50	11.75	10.62	8	0.88	1.06	45
10	16.00	14.25	12.75	12	1.00	1.12	70
12	19.00	17.00	15.00	12	1.00	1.19	110
14	21.00	18.75	16.25	12	1.12	1.31	140
16	23.50	21.25	18.50	16	1.12	1.38	180
18	25.00	22.75	21.00	16	1.25	1.50	220
20	27.50	25.00	23.00	20	1.25	1.62	285
22	29.50	27.25	25.25	20	1.38	1.75	355
24	32.00	29.50	27.25	20	1.38	1.81	430

(a) All dimensions are in inches

(b) These flanges will be furnished with a 1/16" raised face unless otherwise specified.

ANSI B16.5 Flanges

▶ Class 300 Blind Flanges

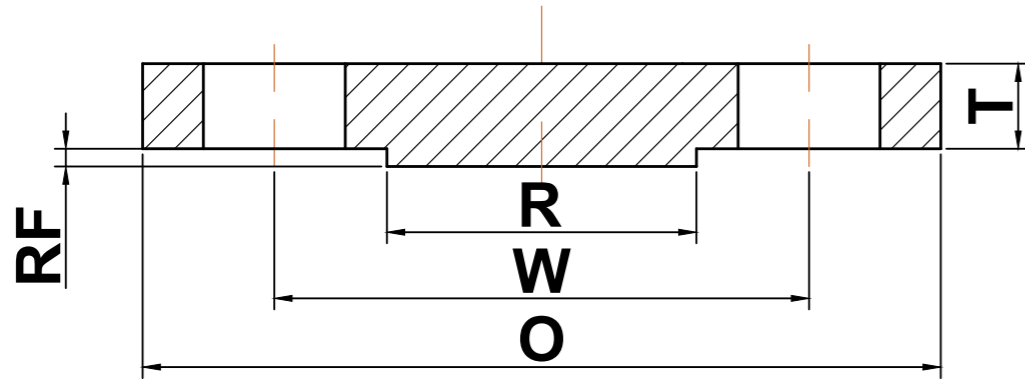

Nominal Pipe Size	Outside Diameter (O)	Bolt Circle (W)	Raised Face Diameter (R)	Number of Holes	Diameter of Holes	Thickness (T)	Approximate Weight (lbs)
1/2	3.75	2.62	1.38	4	0.63	0.50	2
3/4	4.62	3.25	1.69	4	0.75	0.56	3
1	4.88	3.50	2.00	4	0.75	0.62	3
1 1/4	5.25	3.88	2.50	4	0.75	0.69	4
1 1/2	6.12	4.50	2.88	4	0.88	0.75	6
2	6.50	5.00	3.62	8	0.75	0.81	8
2 1/2	7.50	5.88	4.12	8	0.88	0.94	12
3	8.25	6.62	5.00	8	0.88	1.06	16
3 1/2	9.00	7.25	5.50	8	0.88	1.12	21
4	10.00	7.88	6.19	8	0.88	1.19	27
5	11.00	9.25	7.31	8	0.88	1.31	35
6	12.50	10.62	8.50	12	0.88	1.38	50
8	15.00	13.00	10.62	12	1.00	1.56	81
10	17.50	15.25	12.75	16	1.13	1.81	124
12	20.50	17.75	15.00	16	1.25	1.94	185
14	23.00	20.25	16.25	20	1.25	2.06	250
16	25.50	22.50	18.50	20	1.38	2.19	295
18	28.00	24.75	21.00	24	1.38	2.31	395
20	30.50	27.00	23.00	24	1.38	2.44	505
22	33.00	29.25	25.25	24	1.63	2.56	640
24	36.00	32.00	27.25	24	1.63	2.69	790

(a) All dimensions are in inches

(b) These flanges will be furnished with a 1/16" raised face unless otherwise specified.

ANSI B16.5 Flanges

▶ Class 400 Blind Flanges

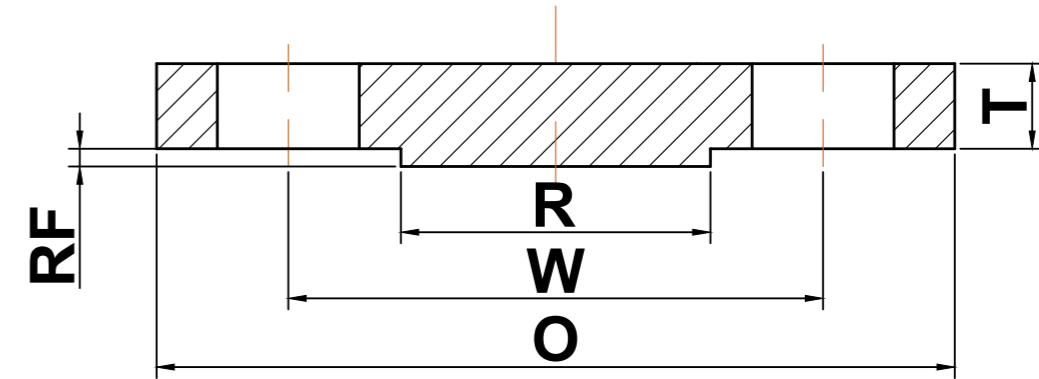

Nominal Pipe Size	Outside Diameter (O)	Bolt Circle (W)	Raised Face Diameter (R)	Number of Holes	Diameter of Holes	Thickness (T)	Approximate Weight (lbs)
1/2	3.75	2.62	1.38	4	0.63	0.56	2
3/4	4.62	3.25	1.69	4	0.75	0.62	3
1	4.88	3.50	2.00	4	0.75	0.69	4
1 1/4	5.25	3.88	2.50	4	0.75	0.81	5
1 1/2	6.12	4.50	2.88	4	0.88	0.88	8
2	6.50	5.00	3.62	8	0.75	1.00	10
2 1/2	7.50	5.88	4.12	8	0.88	1.12	15
3	8.25	6.62	5.00	8	0.88	1.25	20
3 1/2	9.00	7.25	5.50	8	1.00	1.38	29
4	10.00	7.88	6.19	8	1.00	1.38	33
5	11.00	9.25	7.31	8	1.00	1.50	44
6	12.50	10.62	8.50	12	1.00	1.62	61
8	15.00	13.00	10.62	12	1.13	1.88	100
10	17.50	15.25	12.75	16	1.25	2.12	155
12	20.50	17.75	15.00	16	1.38	2.25	225
14	23.00	20.25	16.25	20	1.38	2.38	290
16	25.50	22.50	18.50	20	1.50	2.50	370
18	28.00	24.75	21.00	24	1.50	2.62	455
20	30.50	27.00	23.00	24	1.63	2.75	587
22	33.00	29.25	25.25	24	1.75	2.88	720
24	36.00	32.00	27.25	24	1.88	3.00	890

(a) All dimensions are in inches

(b) These flanges will be furnished with a 1/4" raised face unless otherwise specified.

ANSI B16.5 Flanges

▶ Class 600 Blind Flanges

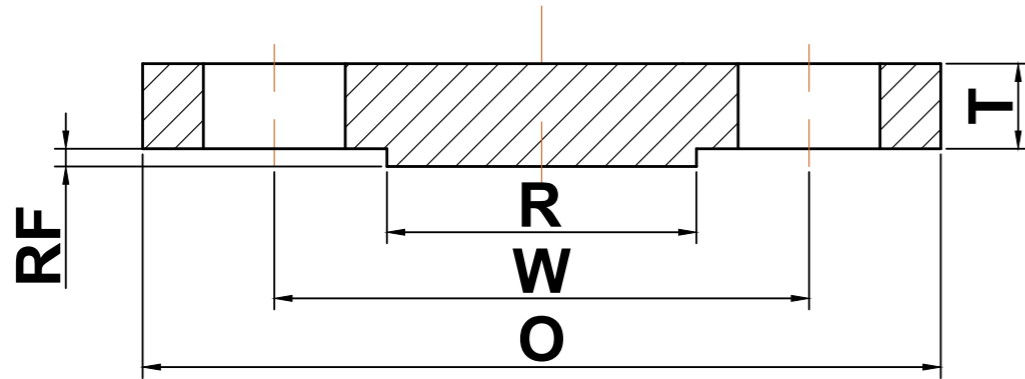

Nominal Pipe Size	Outside Diameter (O)	Bolt Circle (W)	Raised Face Diameter (R)	Number of Holes	Diameter of Holes	Thickness (T)	Approximate Weight (lbs)
1/2	3.75	2.62	1.38	4	0.63	0.56	2
3/4	4.62	3.25	1.69	4	0.75	0.62	3
1	4.88	3.50	2.00	4	0.75	0.69	4
1 1/4	5.25	3.88	2.50	4	0.75	0.81	5
1 1/2	6.12	4.50	2.88	4	0.88	0.88	8
2	6.50	5.00	3.62	8	0.75	1.00	10
2 1/2	7.50	5.88	4.12	8	0.88	1.12	15
3	8.25	6.62	5.00	8	0.88	1.25	20
3 1/2	9.00	7.25	5.50	8	1.00	1.38	29
4	10.75	8.50	6.19	8	1.00	1.50	41
5	13.00	10.50	7.31	8	1.13	1.75	68
6	14.00	11.50	8.50	12	1.13	1.88	86
8	16.50	13.75	10.62	12	1.25	2.19	140
10	20.00	17.00	12.75	16	1.38	2.50	230
12	22.00	19.25	15.00	20	1.38	2.62	295
14	23.75	20.75	16.25	20	1.50	2.75	355
16	27.00	23.75	18.50	20	1.63	3.00	495
18	29.25	25.75	21.00	20	1.75	3.25	630
20	32.00	28.50	23.00	24	1.75	3.50	810
22	34.25	30.62	25.25	24	1.88	3.75	1000
24	37.00	33.00	27.25	24	2.00	4.00	1250

(a) All dimensions are in inches

(b) These flanges will be furnished with a 1/4" raised face unless otherwise specified.

ANSI B16.5 Flanges

▶ Class 900 Blind Flanges

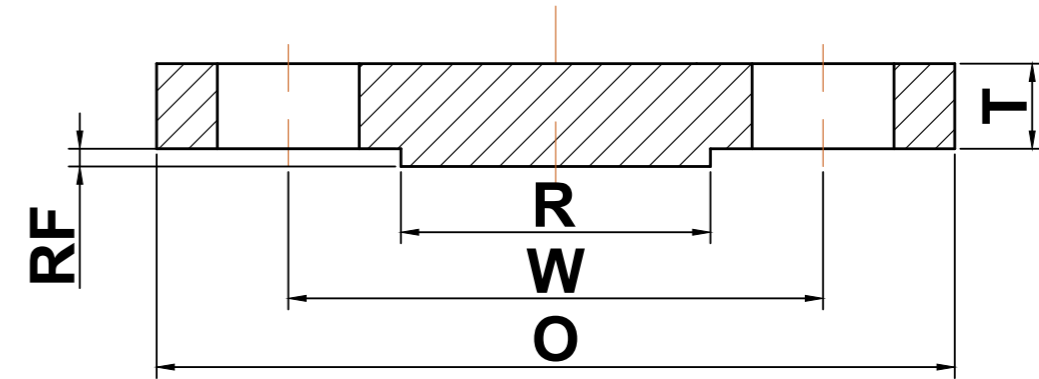

Nominal Pipe Size	Outside Diameter (O)	Bolt Circle (W)	Raised Face Diameter (R)	Number of Holes	Diameter of Holes	Thickness (T)	Approximate Weight (lbs)
1/2	4.75	3.25	1.38	4	0.88	0.88	4
3/4	5.12	3.50	1.69	4	0.88	1.00	6
1	5.88	4.00	2.00	4	1.00	1.12	8
1 1/4	6.25	4.38	2.50	4	1.00	1.12	9
1 1/2	7.00	4.88	2.88	4	1.13	1.25	13
2	8.50	6.50	3.62	8	1.00	1.50	25
2 1/2	9.62	7.50	4.12	8	1.13	1.62	35
3	9.50	7.50	5.00	8	1.00	1.50	29
4	11.50	9.25	6.19	8	1.25	1.75	54
5	13.75	11.00	7.31	8	1.38	2.00	87
6	15.00	12.50	8.50	12	1.25	2.19	115
8	18.50	15.50	10.62	12	1.50	2.50	200
10	21.50	18.50	12.75	16	1.50	2.75	290
12	24.00	21.00	15.00	20	1.50	3.12	415
14	25.25	22.00	16.25	20	1.63	3.38	520
16	27.75	24.25	18.50	20	1.75	3.50	600
18	31.00	27.00	21.00	20	2.00	4.00	850
20	33.75	29.50	23.00	20	2.13	4.25	1075
24	41.00	35.50	27.25	20	2.63	5.50	2025

(a) All dimensions are in inches

(b) These flanges will be furnished with a 1/4" raised face unless otherwise specified.

ANSI B16.5 Flanges

▶ Class 1500 Blind Flanges

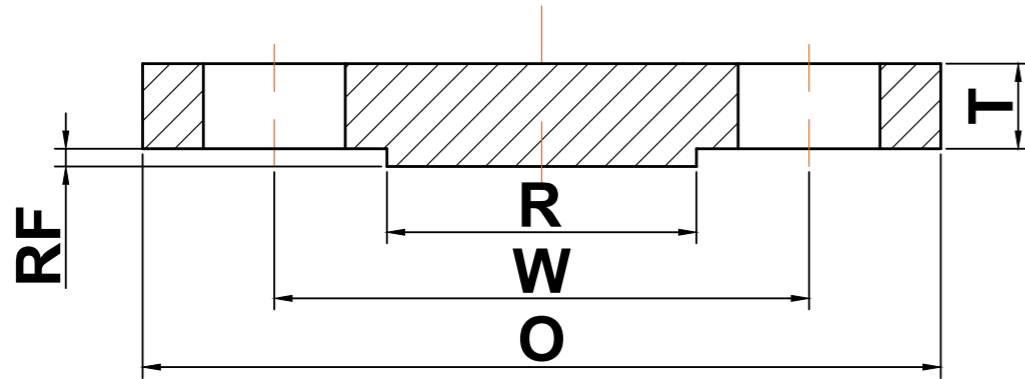

Nominal Pipe Size	Outside Diameter (O)	Bolt Circle (W)	Raised Face Diameter (R)	Number of Holes	Diameter of Holes	Thickness (T)	Approximate Weight (lbs)
1/2	4.75	3.25	1.38	4	0.88	0.88	4
3/4	5.12	3.50	1.69	4	0.88	1.00	6
1	5.88	4.00	2.00	4	1.00	1.12	8
1 1/4	6.25	4.38	2.50	4	1.00	1.12	9
1 1/2	7.00	4.88	2.88	4	1.13	1.25	13
2	8.50	6.50	3.62	8	1.00	1.50	25
2 1/2	9.62	7.50	4.12	8	1.13	1.62	35
3	10.50	8.00	5.00	8	1.25	1.88	48
4	12.25	9.50	6.19	8	1.38	2.12	73
5	14.75	11.50	7.31	8	1.63	2.88	140
6	15.50	12.50	8.50	12	1.50	3.25	160
8	19.00	15.50	10.62	12	1.75	3.62	300
10	23.00	19.00	12.75	12	2.00	4.25	510
12	26.50	22.50	15.00	16	2.13	4.88	690
14	29.50	25.00	16.25	16	2.38	5.25	975
16	32.50	27.75	18.50	16	2.63	5.75	1300
18	36.00	30.50	21.00	16	2.88	6.38	1750
20	38.75	32.75	23.00	16	3.13	7.00	2225
24	46.00	39.00	27.25	16	3.63	8.00	3625

(a) All dimensions are in inches

(b) These flanges will be furnished with a 1/4" raised face unless otherwise specified.

ANSI B16.5 Flanges

▶ Class 2500 Blind Flanges

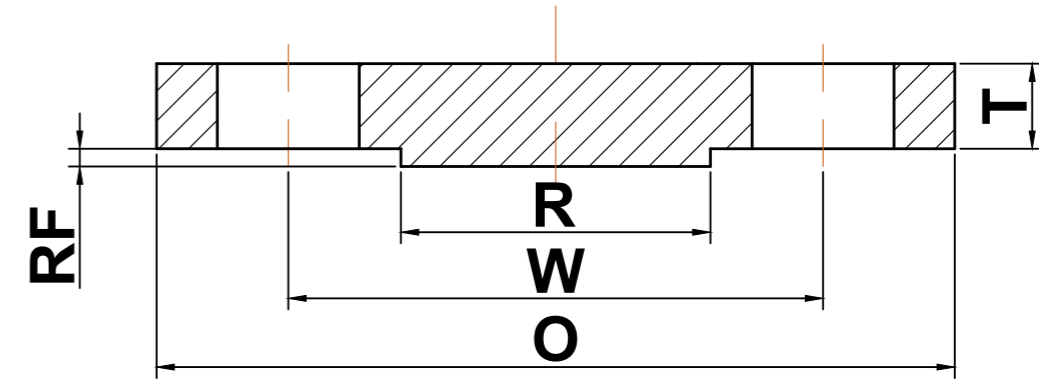

Nominal Pipe Size	Outside Diameter (O)	Bolt Circle (W)	Raised Face Diameter (R)	Number of Holes	Diameter of Holes	Thickness (T)	Approximate Weight (lbs)
1/2	5.25	3.50	1.38	4	0.88	1.19	7
3/4	5.50	3.75	1.69	4	0.88	1.25	8
1	6.25	4.25	2.00	4	1.00	1.38	11
1 1/4	7.25	5.12	2.50	4	1.13	1.50	17
1 1/2	8.00	5.75	2.88	4	1.25	1.75	23
2	9.25	6.75	3.62	8	1.13	2.00	39
2 1/2	10.50	7.75	4.12	8	1.25	2.25	56
3	12.00	9.00	5.00	8	1.38	2.62	86
4	14.00	10.75	6.19	8	1.63	3.00	135
5	16.50	12.75	7.31	8	1.88	3.62	225
6	19.00	14.50	8.50	8	2.13	4.25	345
8	21.75	17.25	10.62	12	2.13	5.00	530
10	26.50	21.25	12.75	12	2.63	6.50	1025
12	30.00	24.38	15.00	12	2.88	7.25	1300

(a) All dimensions are in inches

(b) These flanges will be furnished with a 1/4" raised face unless otherwise specified.

➔ ANSI B16.5 Flanges

➔ ANSI B16.5 Flanges

Socket-Weld Flanges

▶ Class 150 Socket-Weld Flanges

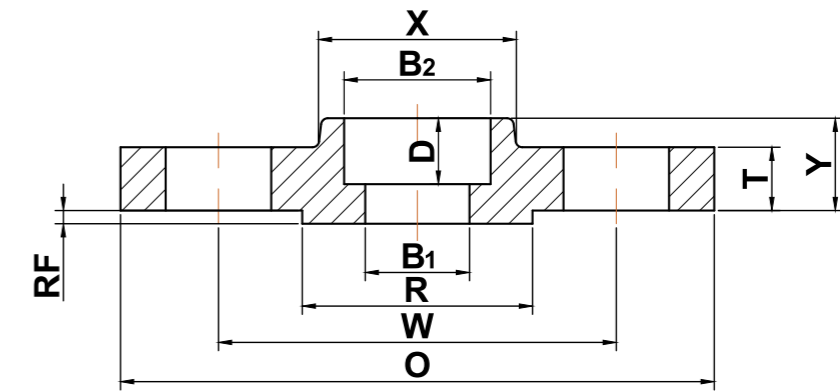

Nominal Pipe Size	Outside Diameter (O)	Bolt Circle (W)	Raised Face Diameter (R)	Number of Holes	Diameter of Holes	Hub Diameter (X)	Bore (B1)	Bore (B2)	Depth of Socket (D)	Thickness (T)	Length Thru Hub (Y)	Approximate Weight (lbs)
1/2	3.50	2.38	1.38	4	0.62	1.19	0.62	0.88	0.38	0.38	0.56	1
3/4	3.88	2.75	1.69	4	0.62	1.50	0.82	1.09	0.44	0.44	0.56	2
1	4.25	3.12	2.00	4	0.62	1.94	1.05	1.36	0.50	0.50	0.62	2
1 1/4	4.62	3.50	2.50	4	0.62	2.31	1.38	1.70	0.56	0.56	0.75	3
1 1/2	5.00	3.88	2.88	4	0.62	2.56	1.61	1.95	0.62	0.62	0.81	3
2	6.00	4.75	3.62	4	0.75	3.06	2.07	2.44	0.69	0.69	0.94	5
2 1/2	7.00	5.50	4.12	4	0.75	3.56	2.47	2.94	0.75	0.81	1.06	7
3	7.50	6.00	5.00	4	0.75	4.25	3.07	3.57	0.81	0.88	1.12	8
3 1/2	8.50	7.00	5.50	8	0.75	4.81	3.55	4.07	0.88	0.88	1.19	11
4	9.00	7.50	6.19	8	0.75	5.31	4.03	4.57	0.94	0.88	1.25	13
5	10.00	8.50	7.31	8	0.88	6.44	5.05	5.66	0.94	0.88	1.38	15
6	11.00	9.50	8.50	8	0.88	7.56	6.07	6.72	1.06	0.94	1.50	19
8	13.50	11.75	10.62	8	0.88	9.69	7.98	8.72	1.25	1.06	1.69	30
10	16.00	14.25	12.75	12	1.00	12.00	10.02	10.88	1.31	1.12	1.88	43
12	19.00	17.00	15.00	12	1.00	14.38	12.00	12.88	1.56	1.19	2.12	64
14	21.00	18.75	16.25	12	1.12	15.75	13.25	14.14	1.63	1.31	2.19	90
16	23.50	21.25	18.50	16	1.12	18.00	15.25	16.16	1.75	1.38	2.44	98
18	25.00	22.75	21.00	16	1.25	19.88	17.25	18.18	1.94	1.50	2.62	130
20	27.50	25.00	23.00	20	1.25	22.00	19.25	20.20	2.13	1.62	2.81	165
22	29.50	27.25	25.25	20	1.38	24.00	21.25	22.22	2.38	1.75	3.06	185
24	32.00	29.50	27.25	20	1.38	26.12	23.25	24.25	2.50	1.81	3.19	220

(a) All dimensions are in inches

(b) These flanges will be furnished with a 1/16" raised face unless otherwise specified.

ANSI B16.5 Flanges

▶ Class 300 Socket-Weld Flanges

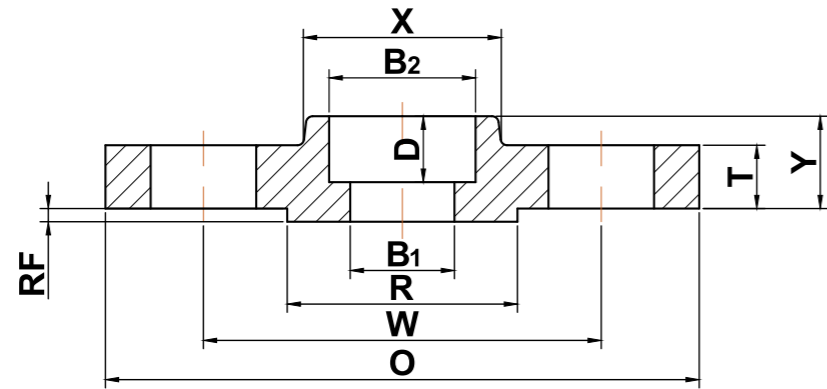

Nominal Pipe Size	Outside Diameter (O)	Bolt Circle (W)	Raised Face Diameter (R)	Number of Holes	Diameter of Holes (D)	Hub Diameter (X)	Bore (B1)	Bore (B2)	Depth of Socket (D)	Thickness (T)	Length Thru Hub (Y)	Approximate Weight (lbs)
1/2	3.75	2.62	1.38	4	0.63	1.50	0.62	0.88	0.38	0.50	0.88	2
3/4	4.62	3.25	1.69	4	0.75	1.88	0.82	1.09	0.44	0.56	1.00	3
1	4.88	3.50	2.00	4	0.75	2.12	1.05	1.36	0.50	0.62	1.06	3
1 1/4	5.25	3.88	2.50	4	0.75	2.50	1.38	1.70	0.56	0.69	1.06	4
1 1/2	6.12	4.50	2.88	4	0.88	2.75	1.61	1.95	0.62	0.75	1.19	6
2	6.50	5.00	3.62	8	0.75	3.31	2.07	2.44	0.69	0.81	1.31	7
2 1/2	7.50	5.88	4.12	8	0.88	3.94	2.47	2.94	0.75	0.94	1.50	10
3	8.25	6.62	5.00	8	0.88	4.62	3.07	3.57	0.81	1.06	1.69	13

(a) All dimensions are in inches

(b) These flanges will be furnished with a 1/16" raised face unless otherwise specified.

ANSI B16.5 Flanges

▶ Class 600 Socket-Weld Flanges

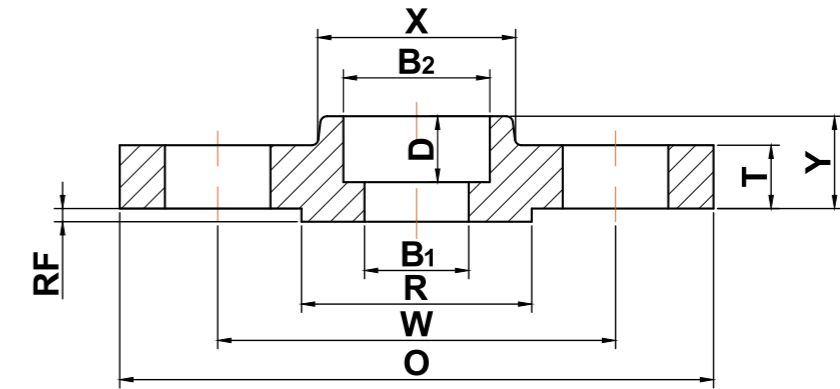

Nominal Pipe Size	Outside Diameter (O)	Bolt Circle (W)	Raised Face Diameter (R)	Number of Holes	Diameter of Holes (D)	Hub Diameter (X)	Bore (B1)	Bore (B2)	Depth of Socket (D)	Thickness (T)	Length Thru Hub (Y)	Approximate Weight (lbs)
1/2	3.75	2.62	1.38	4	0.63	1.50	Specified by Purchaser	0.88	0.38	0.56	0.88	2
3/4	4.62	3.25	1.69	4	0.75	1.88	Specified by Purchaser	1.09	0.44	0.62	1.00	3
1	4.88	3.50	2.00	4	0.75	2.12	Specified by Purchaser	1.36	0.50	0.69	1.06	4
1 1/4	5.25	3.88	2.50	4	0.75	2.50	Specified by Purchaser	1.70	0.56	0.81	1.12	5
1 1/2	6.12	4.50	2.88	4	0.88	2.75	Specified by Purchaser	1.95	0.62	0.88	1.25	7
2	6.50	5.00	3.62	8	0.75	3.31	Specified by Purchaser	2.44	0.69	1.00	1.44	9
2 1/2	7.50	5.88	4.12	8	0.88	3.94	Specified by Purchaser	2.94	0.75	1.12	1.62	13
3	8.25	6.62	5.00	8	0.88	4.62	Specified by Purchaser	3.57	0.81	1.25	1.81	16

(a) All dimensions are in inches

(b) These flanges will be furnished with a 1/4" raised face unless otherwise specified.

ANSI B16.5 Flanges

▶ Class 900 Socket-Weld Flanges

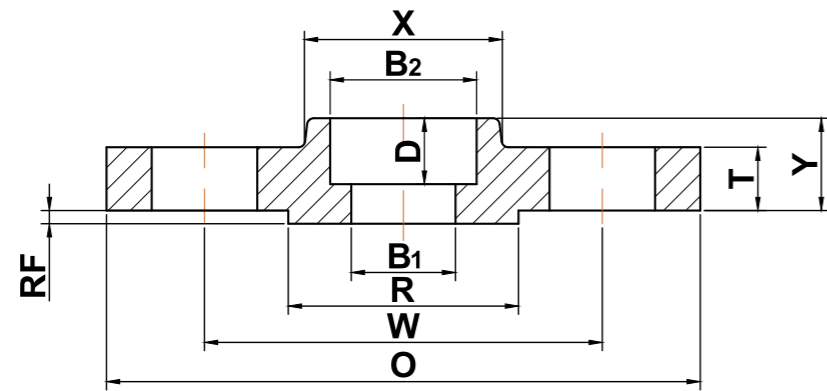

Nominal Pipe Size	Outside Diameter (O)	Bolt Circle (W)	Raised Face Diameter (R)	Number of Holes	Diameter of Holes (D)	Hub Diameter (X)	Bore (B1)	Bore (B2)	Depth of Socket (D)	Thickness (T)	Length Thru Hub (Y)	Approximate Weight (lbs)
1/2	4.75	3.25	1.38	4	0.88	1.50	Specified by Purchaser	0.88	0.38	0.88	1.25	4
3/4	5.12	3.50	1.69	4	0.88	1.75	Specified by Purchaser	1.09	0.44	1.00	1.38	5
1	5.88	4.00	2.00	4	1.00	2.06	Specified by Purchaser	1.36	0.50	1.12	1.62	8
1 1/4	6.25	4.38	2.50	4	1.00	2.50	Specified by Purchaser	1.70	0.56	1.12	1.62	9
1 1/2	7.00	4.88	2.88	4	1.13	2.75	Specified by Purchaser	1.95	0.62	1.25	1.75	12
2	8.50	6.50	3.62	8	1.00	4.12	Specified by Purchaser	2.44	0.69	1.50	2.25	25
2 1/2	9.62	7.50	4.12	8	1.13	4.88	Specified by Purchaser	2.94	0.75	1.62	2.50	36

(a) All dimensions are in inches

(b) These flanges will be furnished with a 1/4" raised face unless otherwise specified.

ANSI B16.5 Flanges

▶ Class 1500 Socket-Weld Flanges

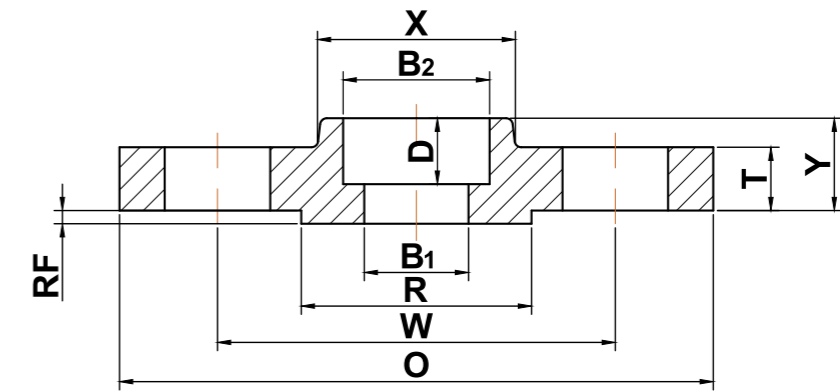

Nominal Pipe Size	Outside Diameter (O)	Bolt Circle (W)	Raised Face Diameter (R)	Number of Holes	Diameter of Holes (D)	Hub Diameter (X)	Bore (B1)	Bore (B2)	Depth of Socket (D)	Thickness (T)	Length Thru Hub (Y)	Approximate Weight (lbs)
1/2	4.75	3.25	1.38	4	0.88	1.50	Specified by Purchaser	0.88	0.38	0.88	1.25	4
3/4	5.12	3.50	1.69	4	0.88	1.75	Specified by Purchaser	1.09	0.44	1.00	1.38	5
1	5.88	4.00	2.00	4	1.00	2.06	Specified by Purchaser	1.36	0.50	1.12	1.62	8
1 1/4	6.25	4.38	2.50	4	1.00	2.50	Specified by Purchaser	1.70	0.56	1.12	1.62	9
1 1/2	7.00	4.88	2.88	4	1.13	2.75	Specified by Purchaser	1.95	0.62	1.25	1.75	12
2	8.50	6.50	3.62	8	1.00	4.12	Specified by Purchaser	2.44	0.69	1.50	2.25	25
2 1/2	9.62	7.50	4.12	8	1.13	4.88	Specified by Purchaser	2.94	0.75	1.62	2.50	36

(a) All dimensions are in inches

(b) These flanges will be furnished with a 1/4" raised face unless otherwise specified.

➔ ANSI B16.5 Flanges

➔ ANSI B16.5 Flanges

▶ Class 150 Lap Joint Flanges

Lap Joint Flanges

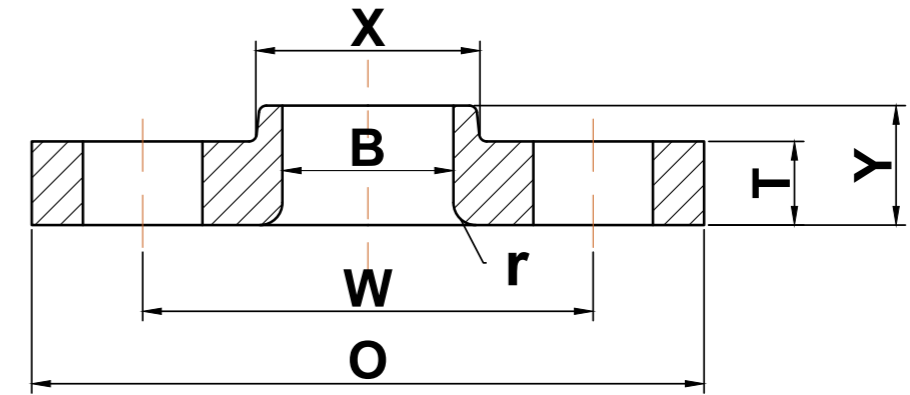

Nominal Pipe Size	Outside Diameter (O)	Bolt Circle (W)	Radius (r)	Number of Holes	Diameter of Holes	Hub Diameter (X)	Bore (B)	Thickness (T)	Length Thru Hub (Y)	Approximate Weight (lbs)
1/2	3.50	2.38	0.12	4	0.62	1.19	0.90	0.44	0.62	1
3/4	3.88	2.75	0.12	4	0.62	1.50	1.11	0.50	0.62	2
1	4.25	3.12	0.12	4	0.62	1.94	1.36	0.56	0.69	2
1 1/4	4.62	3.50	0.19	4	0.62	2.31	1.70	0.62	0.81	3
1 1/2	5.00	3.88	0.25	4	0.62	2.56	1.95	0.69	0.88	3
2	6.00	4.75	0.31	4	0.75	3.06	2.44	0.75	1.00	5
2 1/2	7.00	5.50	0.31	4	0.75	3.56	2.97	0.88	1.12	7
3	7.50	6.00	0.38	4	0.75	4.25	3.60	0.94	1.19	8
3 1/2	8.50	7.00	0.38	8	0.75	4.81	4.10	0.94	1.25	11
4	9.00	7.50	0.44	8	0.75	5.31	4.60	0.94	1.31	13
5	10.00	8.50	0.44	8	0.88	6.44	5.69	0.94	1.44	15
6	11.00	9.50	0.50	8	0.88	7.56	6.75	1.00	1.56	19
8	13.50	11.75	0.50	8	0.88	9.69	8.75	1.12	1.75	30
10	16.00	14.25	0.50	12	1.00	12.00	10.92	1.19	1.94	43
12	19.00	17.00	0.50	12	1.00	14.38	12.92	1.25	2.19	64
14	21.00	18.75	0.50	12	1.12	15.75	14.18	1.38	3.12	105
16	23.50	21.25	0.50	16	1.12	18.00	16.19	1.44	3.44	140
18	25.00	22.75	0.50	16	1.25	19.88	18.20	1.56	3.81	160
20	27.50	25.00	0.50	20	1.25	22.00	20.25	1.69	4.06	195
22	29.50	27.25	0.50	20	1.38	24.00	22.25	1.81	4.25	245
24	32.00	29.50	0.50	20	1.38	26.12	24.25	1.88	4.38	275

(a) All dimensions are in inches

ANSI B16.5 Flanges

▶ Class 300 Lap Joint Flanges

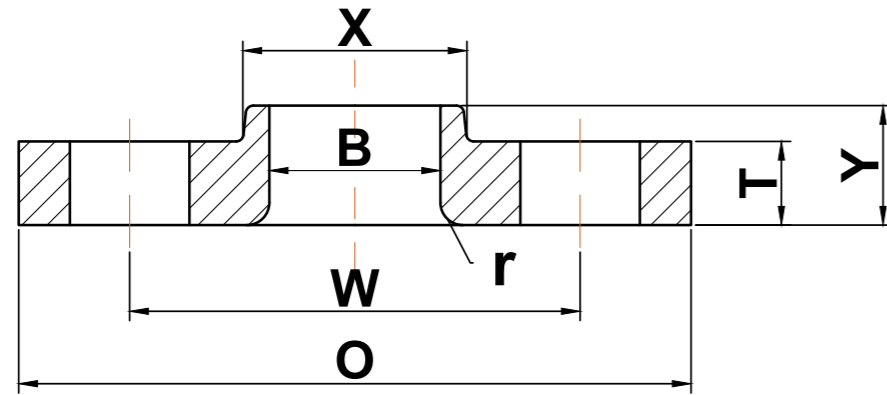

Nominal Pipe Size	Outside Diameter (O)	Bolt Circle (W)	Radius (r)	Number of Holes	Diameter of Holes	Hub Diameter (X)	Bore (B)	Thickness (T)	Length Thru Hub (Y)	Approximate Weight (lbs)
1/2	3.75	2.62	0.12	4	0.63	1.50	0.90	0.56	0.88	2
3/4	4.62	3.25	0.12	4	0.75	1.88	1.11	0.62	1.00	3
1	4.88	3.50	0.12	4	0.75	2.12	1.38	0.69	1.06	3
1 1/4	5.25	3.88	0.19	4	0.75	2.50	1.72	0.75	1.06	4
1 1/2	6.12	4.50	0.25	4	0.88	2.75	1.97	0.81	1.19	6
2	6.50	5.00	0.31	8	0.75	3.31	2.46	0.88	1.31	7
2 1/2	7.50	5.88	0.31	8	0.88	3.94	2.97	1.00	1.50	10
3	8.25	6.62	0.38	8	0.88	4.62	3.60	1.12	1.69	13
3 1/2	9.00	7.25	0.38	8	0.88	5.25	4.10	1.19	1.75	17
4	10.00	7.88	0.44	8	0.88	5.75	4.60	1.25	1.88	22
5	11.00	9.25	0.44	8	0.88	7.00	5.69	1.38	2.00	28
6	12.50	10.62	0.50	12	0.88	8.12	6.75	1.44	2.06	39
8	15.00	13.00	0.50	12	1.00	10.25	8.75	1.62	2.44	58
10	17.50	15.25	0.50	16	1.13	12.62	10.92	1.88	3.75	91
12	20.50	17.75	0.50	16	1.25	14.75	12.92	2.00	4.00	140
14	23.00	20.25	0.50	20	1.25	16.75	14.18	2.12	4.38	190
16	25.50	22.50	0.50	20	1.38	19.00	16.19	2.25	4.75	250
18	28.00	24.75	0.50	24	1.38	21.00	18.20	2.38	5.12	295
20	30.50	27.00	0.50	24	1.38	23.12	20.25	2.50	5.50	370
22	33.00	29.25	0.50	24	1.63	25.25	22.25	2.62	5.69	435
24	36.00	32.00	0.50	24	1.63	27.62	24.25	2.75	6.00	550

(a) All dimensions are in inches

ANSI B16.5 Flanges

▶ Class 400 Lap Joint Flanges

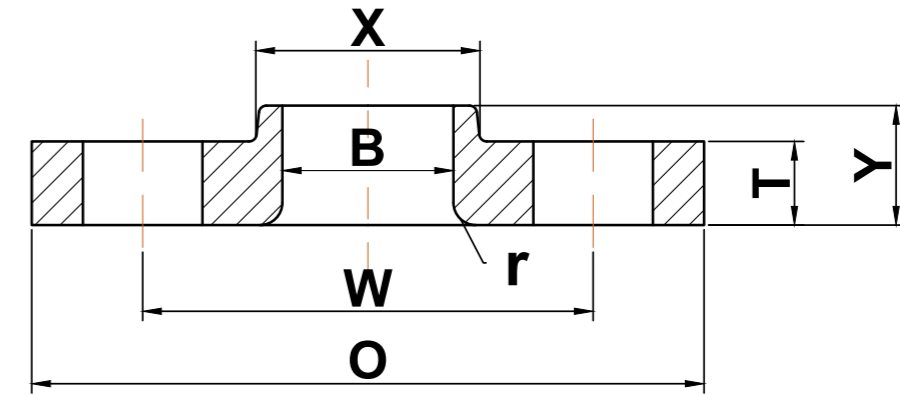

Nominal Pipe Size	Outside Diameter (O)	Bolt Circle (W)	Radius (r)	Number of Holes	Diameter of Holes	Hub Diameter (X)	Bore (B)	Thickness (T)	Length Thru Hub (Y)	Approximate Weight (lbs)
1/2	3.75	2.62	0.12	4	0.63	1.50	0.90	0.56	0.88	2
3/4	4.62	3.25	0.12	4	0.75	1.88	1.11	0.62	1.00	3
1	4.88	3.50	0.12	4	0.75	2.12	1.38	0.69	1.06	4
1 1/4	5.25	3.88	0.19	4	0.75	2.50	1.72	0.81	1.12	5
1 1/2	6.12	4.50	0.25	4	0.88	2.75	1.97	0.88	1.25	7
2	6.50	5.00	0.31	8	0.75	3.31	2.46	1.00	1.44	9
2 1/2	7.50	5.88	0.31	8	0.88	3.94	2.97	1.12	1.62	12
3	8.25	6.62	0.38	8	0.88	4.62	3.60	1.25	1.81	15
3 1/2	9.00	7.25	0.38	8	1.00	5.25	4.10	1.38	1.94	20
4	10.00	7.88	0.44	8	1.00	5.75	4.60	1.38	2.00	25
5	11.00	9.25	0.44	8	1.00	7.00	5.69	1.50	2.12	29
6	12.50	10.62	0.50	12	1.00	8.12	6.75	1.62	2.25	42
8	15.00	13.00	0.50	12	1.13	10.25	8.75	1.88	2.69	64
10	17.50	15.25	0.50	16	1.25	12.62	10.92	2.12	4.00	110
12	20.50	17.75	0.50	16	1.38	14.75	12.92	2.25	4.25	150
14	23.00	20.25	0.50	20	1.38	16.75	14.18	2.38	4.62	205
16	25.50	22.50	0.50	20	1.50	19.00	16.19	2.50	5.00	260
18	28.00	24.75	0.50	24	1.50	21.00	18.20	2.62	5.38	315
20	30.50	27.00	0.50	24	1.63	23.13	20.25	2.75	5.75	385
22	33.00	29.25	0.50	24	1.75	25.25	22.25	2.88	6.00	455
24	36.00	32.00	0.50	24	1.88	27.62	24.25	3.00	6.25	570

(a) All dimensions are in inches

ANSI B16.5 Flanges

▶ Class 600 Lap Joint Flanges

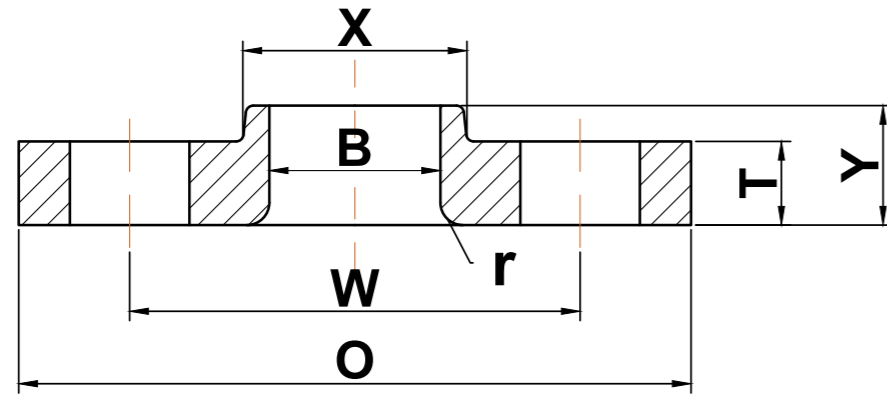

Nominal Pipe Size	Outside Diameter (O)	Bolt Circle (W)	Radius (r)	Number of Holes	Diameter of Holes	Hub Diameter (X)	Bore (B)	Thickness (T)	Length Thru Hub (Y)	Approximate Weight (lbs)
1/2	3.75	2.62	0.12	4	0.63	1.50	0.90	0.56	0.88	2
3/4	4.62	3.25	0.12	4	0.75	1.88	1.11	0.62	1.00	3
1	4.88	3.50	0.12	4	0.75	2.12	1.38	0.69	1.06	4
1 1/4	5.25	3.88	0.19	4	0.75	2.50	1.72	0.81	1.12	5
1 1/2	6.12	4.50	0.25	4	0.88	2.75	1.97	0.88	1.25	7
2	6.50	5.00	0.31	8	0.75	3.31	2.46	1.00	1.44	9
2 1/2	7.50	5.88	0.31	8	0.88	3.94	2.97	1.12	1.62	12
3	8.25	6.62	0.38	8	0.88	4.62	3.60	1.25	1.81	15
3 1/2	9.00	7.25	0.38	8	1.00	5.25	4.10	1.38	1.94	20
4	10.75	8.50	0.44	8	1.00	6.00	4.60	1.50	2.12	36
5	13.00	10.50	0.44	8	1.13	7.44	5.69	1.75	2.38	61
6	14.00	11.50	0.50	12	1.13	8.75	6.75	1.88	2.62	78
8	16.50	13.75	0.50	12	1.25	10.75	8.75	2.19	3.00	110
10	20.00	17.00	0.50	16	1.38	13.50	10.92	2.50	4.38	170
12	22.00	19.25	0.50	20	1.38	15.75	12.92	2.62	4.62	200
14	23.75	20.75	0.50	20	1.50	17.00	14.18	2.75	5.00	250
16	27.00	23.75	0.50	20	1.63	19.50	16.19	3.00	5.50	365
18	29.25	25.75	0.50	20	1.75	21.50	18.20	3.25	6.00	435
20	32.00	28.50	0.50	24	1.75	24.00	20.25	3.50	6.50	570
22	34.25	30.62	0.50	24	1.88	26.25	22.25	3.75	6.88	670
24	37.00	33.00	0.50	24	2.00	28.25	24.25	4.00	7.25	810

(a) All dimensions are in inches

ANSI B16.5 Flanges

▶ Class 900 Lap Joint Flanges

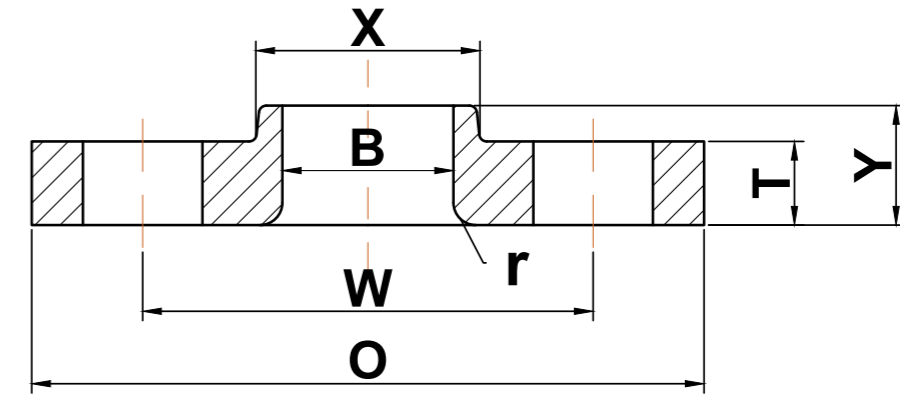

Nominal Pipe Size	Outside Diameter (O)	Bolt Circle (W)	Radius (r)	Number of Holes	Diameter of Holes	Hub Diameter (X)	Bore (B)	Thickness (T)	Length Thru Hub (Y)	Approximate Weight (lbs)
1/2	4.75	3.25	0.12	4	0.88	1.50	0.90	0.88	1.25	4
3/4	5.12	3.50	0.12	4	0.88	1.75	1.11	1.00	1.38	5
1	5.88	4.00	0.12	4	1.00	2.06	1.38	1.12	1.62	8
1 1/4	6.25	4.38	0.19	4	1.00	2.50	1.72	1.12	1.62	9
1 1/2	7.00	4.88	0.25	4	1.13	2.75	1.97	1.25	1.75	12
2	8.50	6.50	0.31	8	1.00	4.12	2.46	1.50	2.25	25
2 1/2	9.62	7.50	0.31	8	1.13	4.88	2.97	1.62	2.50	35
3	9.50	7.50	0.38	8	1.00	5.00	3.60	1.50	2.12	25
4	11.50	9.25	0.44	8	1.25	6.25	4.60	1.75	2.75	51
5	13.75	11.00	0.50	8	1.38	7.50	5.69	2.00	3.12	81
6	15.00	12.50	0.50	12	1.25	9.25	6.75	2.19	3.38	105
8	18.50	15.50	0.50	12	1.50	11.75	8.75	2.50	4.50	190
10	21.50	18.50	0.50	16	1.50	14.50	10.92	2.75	5.00	275
12	24.00	21.00	0.50	20	1.50	16.50	12.92	3.12	5.62	370
14	25.25	22.00	0.50	20	1.63	17.75	14.18	3.38	6.12	415
16	27.75	24.25	0.50	20	1.75	20.00	16.19	3.50	6.50	465
18	31.00	27.00	0.50	20	2.00	22.25	18.20	4.00	7.50	650
20	33.75	29.50	0.50	20	2.13	24.50	20.25	4.25	8.25	810
24	41.00	35.50	0.50	20	2.63	29.50	24.25	5.50	10.50	1550

(a) All dimensions are in inches

ANSI B16.5 Flanges

▶ Class 1500 Lap Joint Flanges

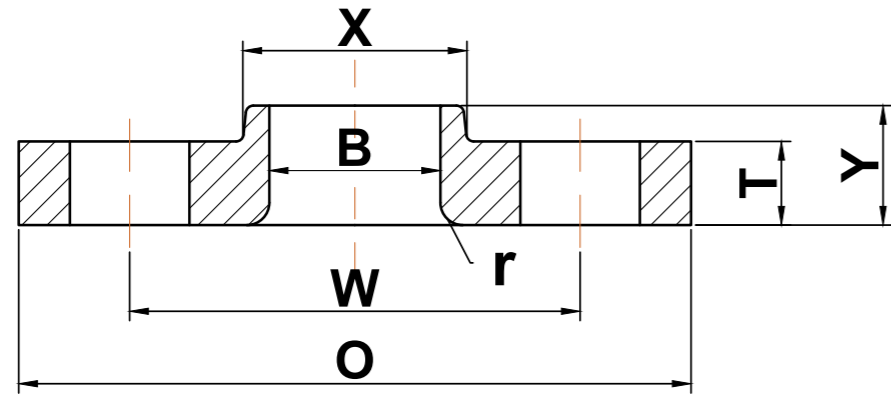

Nominal Pipe Size	Outside Diameter (O)	Bolt Circle (W)	Radius (r)	Number of Holes	Diameter of Holes	Hub Diameter (X)	Bore (B)	Thickness (T)	Length Thru Hub (Y)	Approximate Weight (lbs)
1/2	4.75	3.25	0.12	4	0.88	1.50	0.90	0.88	1.25	4
3/4	5.12	3.50	0.12	4	0.88	1.75	1.11	1.00	1.38	5
1	5.88	4.00	0.12	4	1.00	2.06	1.38	1.12	1.62	8
1 1/4	6.25	4.38	0.19	4	1.00	2.50	1.72	1.12	1.62	9
1 1/2	7.00	4.88	0.25	4	1.13	2.75	1.97	1.25	1.75	12
2	8.50	6.50	0.31	8	1.00	4.12	2.46	1.50	2.25	25
2 1/2	9.62	7.50	0.31	8	1.13	4.88	2.97	1.62	2.50	35
3	10.50	8.00	0.38	8	1.25	5.25	3.60	1.88	2.88	47
4	12.25	9.50	0.44	8	1.38	6.38	4.60	2.12	3.56	75
5	14.75	11.50	0.44	8	1.63	7.75	5.69	2.88	4.12	140
6	15.50	12.50	0.50	12	1.50	9.00	6.75	3.25	4.69	170
8	19.00	15.50	0.50	12	1.75	11.50	8.75	3.62	5.62	285
10	23.00	19.00	0.50	12	2.00	14.50	10.92	4.25	7.00	485
12	26.50	22.50	0.50	16	2.13	17.75	12.92	4.88	8.62	630
14	29.50	25.00	0.50	16	2.38	19.50	14.18	5.25	9.50	890
16	32.50	27.75	0.50	16	2.63	21.75	16.19	5.75	10.25	1150
18	36.00	30.50	0.50	16	2.88	23.50	18.20	6.38	10.88	1475
20	38.75	32.75	0.50	16	3.13	25.25	20.25	7.00	11.50	1775
24	46.00	39.00	0.50	16	3.63	30.00	24.25	8.00	13.00	2825

(a) All dimensions are in inches

ANSI B16.5 Flanges

▶ Class 2500 Lap Joint Flanges

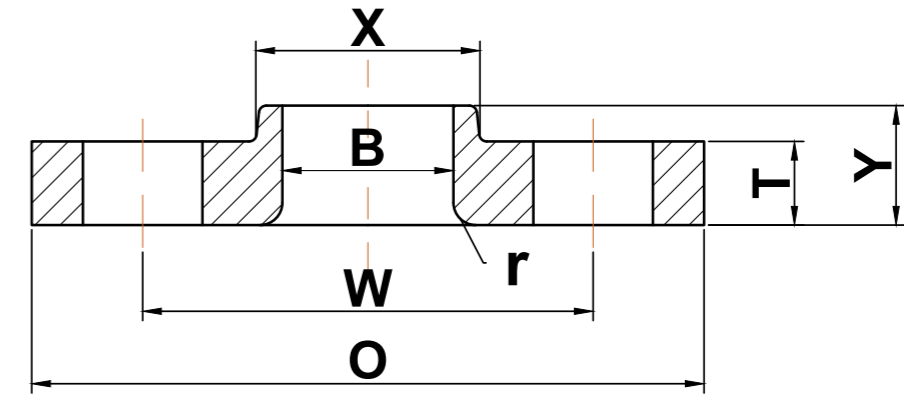

Nominal Pipe Size	Outside Diameter (O)	Bolt Circle (W)	Radius (r)	Number of Holes	Diameter of Holes	Hub Diameter (X)	Bore (B)	Thickness (T)	Length Thru Hub (Y)	Approximate Weight (lbs)
1/2	5.25	3.50	0.12	4	0.88	1.69	0.90	1.19	1.56	7
3/4	5.50	3.75	0.12	4	0.88	2.00	1.11	1.25	1.69	8
1	6.25	4.25	0.12	4	1.00	2.25	1.38	1.38	1.88	11
1 1/4	7.25	5.12	0.19	4	1.13	2.88	1.72	1.50	2.06	16
1 1/2	8.00	5.75	0.25	4	1.25	3.12	1.97	1.75	2.38	22
2	9.25	6.75	0.31	8	1.13	3.75	2.46	2.00	2.75	37
2 1/2	10.50	7.75	0.31	8	1.25	4.50	2.97	2.25	3.12	53
3	12.00	9.00	0.38	8	1.38	5.25	3.60	2.62	3.62	80
4	14.00	10.75	0.44	8	1.63	6.50	4.60	3.00	4.25	120
5	16.50	12.75	0.44	8	1.88	8.00	5.69	3.62	5.12	205
6	19.00	14.50	0.50	8	2.13	9.25	6.75	4.25	6.00	315
8	21.75	17.25	0.50	12	2.13	12.00	8.75	5.00	7.00	470
10	26.50	21.25	0.50	12	2.63	14.75	10.92	6.50	9.00	900
12	30.00	24.38	0.50	12	2.88	17.38	12.92	7.25	10.00	1100

(a) All dimensions are in inches

➔ ANSI B16.5 Flanges

➔ ANSI B16.5 Flanges

▶ Class 150 Threaded Flanges

Threaded Flanges

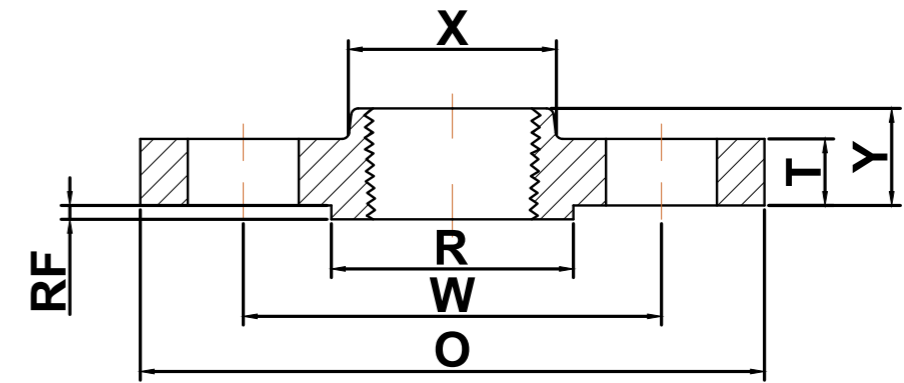

Nominal Pipe Size	Outside Diameter (O)	Bolt Circle (W)	Raised Face Diameter (R)	Number of Holes	Diameter of Holes	Hub Diameter (X)	Thickness (T)	Length Thru Hub (Y)	Approximate Weight (lbs)
1/2	3.50	2.38	1.38	4	0.62	1.19	0.38	0.56	1
3/4	3.88	2.75	1.69	4	0.62	1.50	0.44	0.56	2
1	4.25	3.12	2.00	4	0.62	1.94	0.50	0.62	2
1 1/4	4.62	3.50	2.50	4	0.62	2.31	0.56	0.75	3
1 1/2	5.00	3.88	2.88	4	0.62	2.56	0.62	0.81	3
2	6.00	4.75	3.62	4	0.75	3.06	0.69	0.94	5
2 1/2	7.00	5.50	4.12	4	0.75	3.56	0.81	1.06	7
3	7.50	6.00	5.00	4	0.75	4.25	0.88	1.12	8
3 1/2	8.50	7.00	5.50	8	0.75	4.81	0.88	1.19	11
4	9.00	7.50	6.19	8	0.75	5.31	0.88	1.25	13
5	10.00	8.50	7.31	8	0.88	6.44	0.88	1.38	15
6	11.00	9.50	8.50	8	0.88	7.56	0.94	1.50	19
8	13.50	11.75	10.62	8	0.88	9.69	1.06	1.69	30
10	16.00	14.25	12.75	12	1.00	12.00	1.12	1.88	43
12	19.00	17.00	15.00	12	1.00	14.38	1.19	2.12	64
14	21.00	18.75	16.25	12	1.12	15.75	1.31	2.19	90
16	23.50	21.25	18.50	16	1.12	18.00	1.38	2.44	98
18	25.00	22.75	21.00	16	1.25	19.88	1.50	2.62	130
20	27.50	25.00	23.00	20	1.25	22.00	1.62	2.81	165
22	29.50	27.25	25.25	20	1.38	24.00	1.75	3.06	185
24	32.00	29.50	27.25	20	1.38	26.12	1.81	3.19	220

(a) All dimensions are in inches

(b) These flanges will be furnished with a 1/16" raised face unless otherwise specified.

ANSI B16.5 Flanges

▶ Class 300 Threaded Flanges

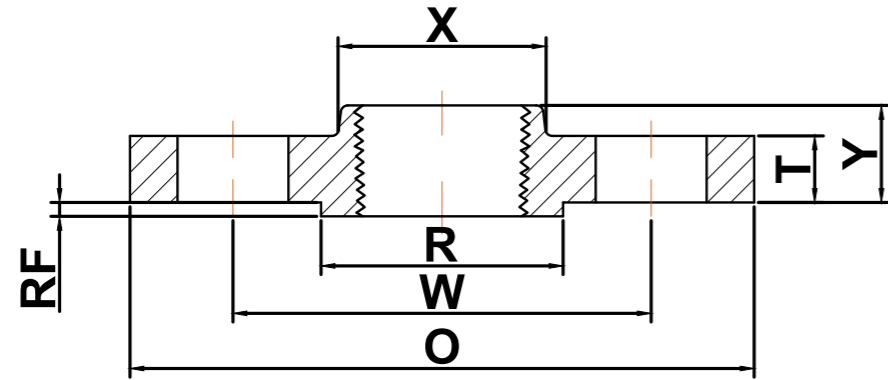

Nominal Pipe Size	Outside Diameter (O)	Bolt Circle (W)	Raised Face Diameter (R)	Number of Holes	Diameter of Holes	Hub Diameter (X)	Thickness (T)	Length Thru Hub (Y)	Approximate Weight (lbs)
1/2	3.75	2.62	1.38	4	0.63	1.50	0.50	0.81	2
3/4	4.62	3.25	1.69	4	0.75	1.88	0.56	0.94	3
1	4.88	3.50	2.00	4	0.75	2.12	0.62	1.00	3
1 1/4	5.25	3.88	2.50	4	0.75	2.50	0.69	1.00	4
1 1/2	6.12	4.50	2.88	4	0.88	2.75	0.75	1.13	6
2	6.50	5.00	3.62	8	0.75	3.31	0.81	1.25	7
2 1/2	7.50	5.88	4.12	8	0.88	3.94	0.94	1.44	10
3	8.25	6.62	5.00	8	0.88	4.62	1.06	1.63	13
3 1/2	9.00	7.25	5.50	8	0.88	5.25	1.12	1.69	17
4	10.00	7.88	6.19	8	0.88	5.75	1.19	1.82	22
5	11.00	9.25	7.31	8	0.88	7.00	1.31	1.94	28
6	12.50	10.62	8.50	12	0.88	8.12	1.38	2.00	39
8	15.00	13.00	10.62	12	1.00	10.25	1.56	2.38	58
10	17.50	15.25	12.75	16	1.13	12.62	1.81	2.56	81
12	20.50	17.75	15.00	16	1.25	14.75	1.94	2.82	115
14	23.00	20.25	16.25	20	1.25	16.75	2.06	2.94	165
16	25.50	22.50	18.50	20	1.38	19.00	2.19	3.19	190
18	28.00	24.75	21.00	24	1.38	21.00	2.31	3.44	250
20	30.50	27.00	23.00	24	1.38	23.12	2.44	3.69	315
22	33.00	29.25	25.25	24	1.63	25.25	2.56	3.94	370
24	36.00	32.00	27.25	24	1.63	27.62	2.69	4.13	475

(a) All dimensions are in inches

(b) These flanges will be furnished with a 1/16" raised face unless otherwise specified.

ANSI B16.5 Flanges

▶ Class 400 Threaded Flanges

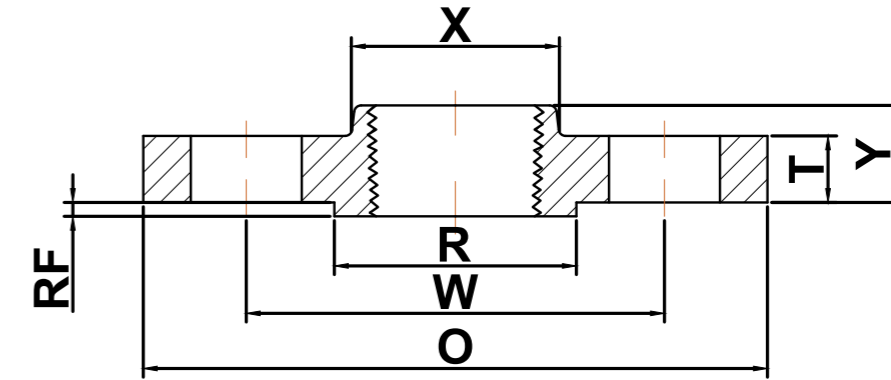

Nominal Pipe Size	Outside Diameter (O)	Bolt Circle (W)	Raised Face Diameter (R)	Number of Holes	Diameter of Holes	Hub Diameter (X)	Thickness (T)	Length Thru Hub (Y)	Approximate Weight (lbs)
1/2	3.75	2.62	1.38	4	0.63	1.50	0.56	0.88	2
3/4	4.62	3.25	1.69	4	0.75	1.88	0.62	1.00	3
1	4.88	3.50	2.00	4	0.75	2.12	0.69	1.06	4
1 1/4	5.25	3.88	2.50	4	0.75	2.50	0.81	1.12	5
1 1/2	6.12	4.50	2.88	4	0.88	2.75	0.88	1.25	7
2	6.50	5.00	3.62	8	0.75	3.31	1.00	1.44	9
2 1/2	7.50	5.88	4.12	8	0.88	3.94	1.12	1.62	13
3	8.25	6.62	5.00	8	0.88	4.62	1.25	1.81	16
3 1/2	9.00	7.25	5.50	8	1.00	5.25	1.38	1.94	21
4	10.00	7.88	6.19	8	1.00	5.75	1.38	2.00	26
5	11.00	9.25	7.31	8	1.00	7.00	1.50	2.12	31
6	12.50	10.62	8.50	12	1.00	8.12	1.62	2.25	44
8	15.00	13.00	10.62	12	1.13	10.25	1.88	2.69	67
10	17.50	15.25	12.75	16	1.25	12.62	2.12	2.88	91
12	20.50	17.75	15.00	16	1.38	14.75	2.25	3.12	130
14	23.00	20.25	16.25	20	1.38	16.75	2.38	3.31	180
16	25.50	22.50	18.50	20	1.50	19.00	2.50	3.69	235
18	28.00	24.75	21.00	24	1.50	21.00	2.62	3.88	285
20	30.50	27.00	23.00	24	1.63	23.13	2.75	4.00	345
22	33.00	29.25	25.25	24	1.75	25.25	2.88	4.25	405
24	36.00	32.00	27.25	24	1.88	27.62	3.00	4.50	510

(a) All dimensions are in inches

(b) These flanges will be furnished with a 1/4" raised face unless otherwise specified.

ANSI B16.5 Flanges

▶ Class 600 Threaded Flanges

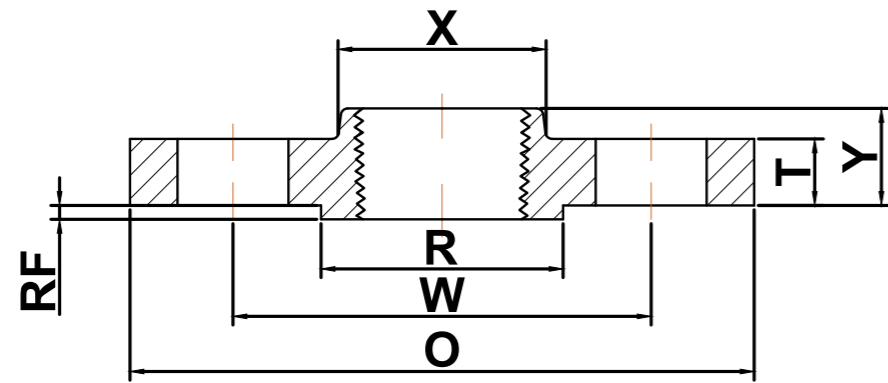

Nominal Pipe Size	Outside Diameter (O)	Bolt Circle (W)	Raised Face Diameter (R)	Number of Holes	Diameter of Holes	Hub Diameter (X)	Thickness (T)	Length Thru Hub (Y)	Approximate Weight (lbs)
1/2	3.75	2.62	1.38	4	0.63	1.50	0.56	0.88	2
3/4	4.62	3.25	1.69	4	0.75	1.88	0.62	1.00	3
1	4.88	3.50	2.00	4	0.75	2.12	0.69	1.06	4
1 1/4	5.25	3.88	2.50	4	0.75	2.50	0.81	1.12	5
1 1/2	6.12	4.50	2.88	4	0.88	2.75	0.88	1.25	7
2	6.50	5.00	3.62	8	0.75	3.31	1.00	1.44	9
2 1/2	7.50	5.88	4.12	8	0.88	3.94	1.12	1.62	13
3	8.25	6.62	5.00	8	0.88	4.62	1.25	1.81	16
3 1/2	9.00	7.25	5.50	8	1	5.25	1.38	1.94	21
4	10.75	8.50	6.19	8	1	6.00	1.50	2.12	37
5	13.00	10.50	7.31	8	1.13	7.44	1.75	2.38	63
6	14.00	11.50	8.50	12	1.13	8.75	1.88	2.62	80
8	16.50	13.75	10.62	12	1.25	10.75	2.19	3.00	115
10	20.00	17.00	12.75	16	1.38	13.50	2.50	3.38	170
12	22.00	19.25	15.00	20	1.38	15.75	2.62	3.62	200
14	23.75	20.75	16.25	20	1.5	17.00	2.75	3.69	230
16	27.00	23.75	18.50	20	1.63	19.50	3.00	4.19	330
18	29.25	25.75	21.00	20	1.75	21.50	3.25	4.62	400
20	32.00	28.50	23.00	24	1.75	24.00	3.50	5.00	510
22	34.25	30.62	25.25	24	1.88	26.25	3.75	5.25	590
24	37.00	33.00	27.25	24	2	28.25	4.00	5.50	730

(a) All dimensions are in inches

(b) These flanges will be furnished with a 1/4" raised face unless otherwise specified.

ANSI B16.5 Flanges

▶ Class 900 Threaded Flanges

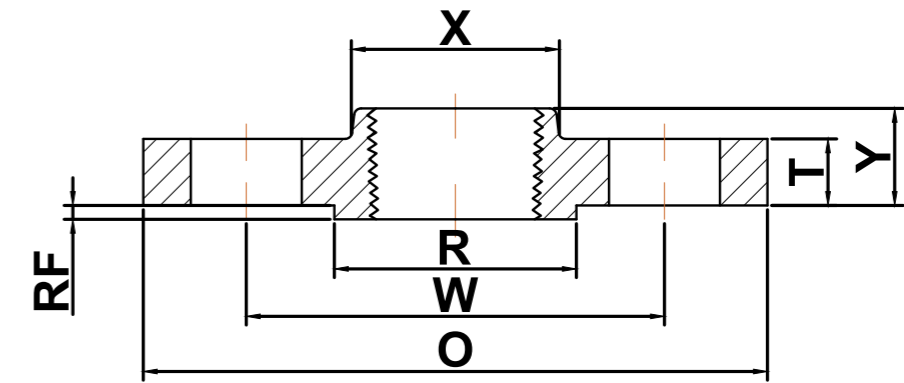

Nominal Pipe Size	Outside Diameter (O)	Bolt Circle (W)	Raised Face Diameter (R)	Number of Holes	Diameter of Holes	Hub Diameter (X)	Thickness (T)	Length Thru Hub (Y)	Approximate Weight (lbs)
1/2	4.75	3.25	1.38	4	0.88	1.50	0.88	1.25	4
3/4	5.12	3.50	1.69	4	0.88	1.75	1.00	1.38	5
1	5.88	4.00	2.00	4	1.00	2.06	1.12	1.62	8
1 1/4	6.25	4.38	2.50	4	1.00	2.50	1.12	1.62	9
1 1/2	7.00	4.88	2.88	4	1.13	2.75	1.25	1.75	12
2	8.50	6.50	3.62	8	1.00	4.12	1.50	2.25	25
2 1/2	9.62	7.50	4.12	8	1.13	4.88	1.62	2.50	36
3	9.50	7.50	5.00	8	1.00	5.00	1.50	2.12	26
4	11.50	9.25	6.19	8	1.25	6.25	1.75	2.75	53
5	13.75	11.00	7.31	8	1.38	7.50	2.00	3.12	83
6	15.00	12.50	8.50	12	1.25	9.25	2.19	3.38	110
8	18.50	15.50	10.62	12	1.50	11.75	2.50	4.00	170
10	21.50	18.50	12.75	16	1.50	14.50	2.75	4.25	245
12	24.00	21.00	15.00	20	1.50	16.50	3.12	4.62	325
14	25.25	22.00	16.25	20	1.63	17.75	3.38	5.12	400
16	27.75	24.25	18.50	20	1.75	20.00	3.50	5.25	425
18	31.00	27.00	21.00	20	2.00	22.25	4.00	6.00	600
20	33.75	29.50	23.00	20	2.13	24.50	4.25	6.25	730
24	41.00	35.50	27.25	20	2.63	29.50	5.50	8.00	1400

(a) All dimensions are in inches

(b) These flanges will be furnished with a 1/4" raised face unless otherwise specified.

ANSI B16.5 Flanges

▶ Class 1500 Threaded Flanges

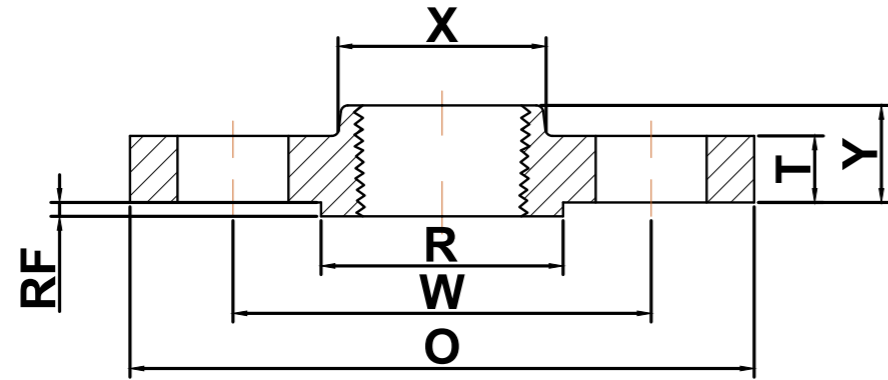

Nominal Pipe Size	Outside Diameter (O)	Bolt Circle (W)	Raised Face Diameter (R)	Number of Holes	Diameter of Holes	Hub Diameter (X)	Thickness (T)	Length Thru Hub (Y)	Approximate Weight (lbs)
1/2	4.75	3.25	1.38	4	0.88	1.50	0.88	1.25	4
3/4	5.12	3.50	1.69	4	0.88	1.75	1.00	1.38	5
1	5.88	4.00	2.00	4	1.00	2.06	1.12	1.62	8
1 1/4	6.25	4.38	2.50	4	1.00	2.50	1.12	1.62	9
1 1/2	7.00	4.88	2.88	4	1.13	2.75	1.25	1.75	12
2	8.50	6.50	3.62	8	1.00	4.12	1.50	2.25	25
2 1/2	9.62	7.50	4.12	8	1.13	4.88	1.62	2.50	36

(a) All dimensions are in inches

(b) These flanges will be furnished with a 1/4" raised face unless otherwise specified.

ANSI B16.5 Flanges

▶ Class 2500 Threaded Flanges

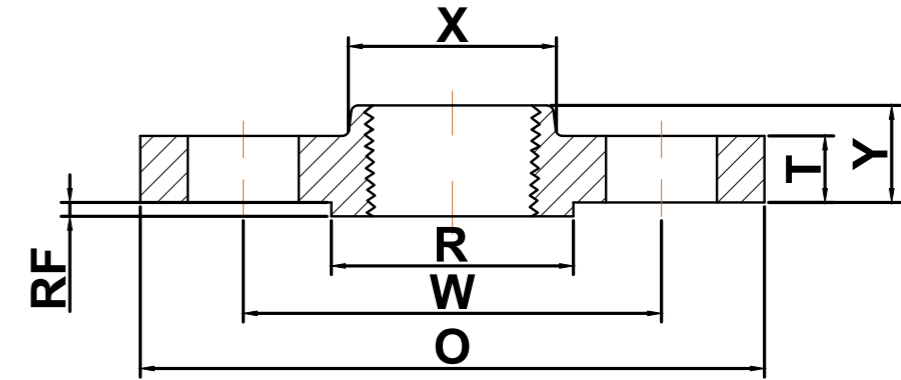

Nominal Pipe Size	Outside Diameter (O)	Bolt Circle (W)	Raised Face Diameter (R)	Number of Holes	Diameter of Holes	Hub Diameter (X)	Thickness (T)	Length Thru Hub (Y)	Approximate Weight (lbs)
1/2	5.25	3.50	1.38	4	0.88	1.69	1.19	1.56	7
3/4	5.50	3.75	1.69	4	0.88	2.00	1.25	1.69	8
1	6.25	4.25	2.00	4	1.00	2.25	1.38	1.88	11
1 1/4	7.25	5.12	2.50	4	1.13	2.88	1.50	2.06	16
1 1/2	8.00	5.75	2.88	4	1.25	3.12	1.75	2.38	22
2	9.25	6.75	3.62	8	1.13	3.75	2.00	2.75	38
2 1/2	10.50	7.75	4.12	8	1.25	4.50	2.25	3.12	55

(a) All dimensions are in inches

(b) These flanges will be furnished with a 1/4" raised face unless otherwise specified.

➔ ASME B16.47 series A flange

➔ ASME B16.47 series A flange

▶ Class 150 Welding Neck Flanges

Welding Neck Flanges

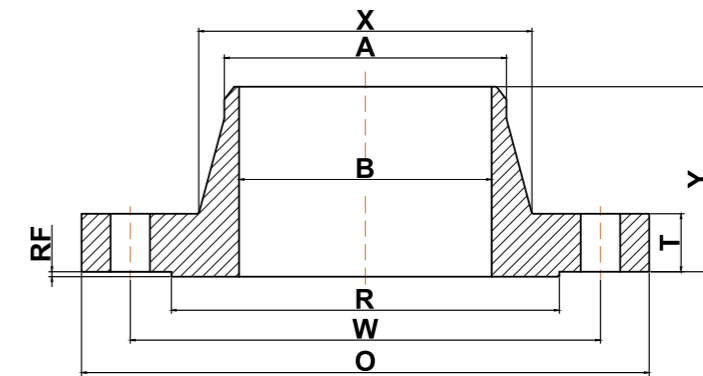

Nominal Pipe Size	Outside Diameter (O)	Bolt Circle (W)	Raised Face Diameter (R)	Number of Holes	Diameter of Holes	Bore (B)	Top of Hub (A)	Hub Diameter (X)	Minimum Fillet Radius (r)	Minimum Thickness (T)	Length Thru Hub (Y)	Approximate Weight (lbs)
26	34.25	31.75	29.50	24	1.38	Specified by purchaser	26.00	26.62	0.38	2.69	4.75	300
28	36.50	34.00	31.50	28	1.38	Specified by purchaser	28.00	28.62	0.44	2.81	4.94	345
30	38.75	36.00	33.75	28	1.38	Specified by purchaser	30.00	30.75	0.44	2.94	5.38	400
32	41.75	38.50	36.00	28	1.62	Specified by purchaser	32.00	32.75	0.44	3.19	5.69	505
34	43.75	40.50	38.00	32	1.62	Specified by purchaser	34.00	34.75	0.50	3.25	5.88	540
36	46.00	42.75	40.25	32	1.62	Specified by purchaser	36.00	36.75	0.50	3.56	6.19	640
38	48.75	45.25	42.25	32	1.62	Specified by purchaser	38.00	39.00	0.50	3.44	6.19	720
40	50.75	47.25	44.25	36	1.62	Specified by purchaser	40.00	41.00	0.50	3.56	6.44	775
42	53.00	49.50	47.00	36	1.62	Specified by purchaser	42.00	43.00	0.50	3.81	6.75	890
44	55.25	51.75	49.00	40	1.62	Specified by purchaser	44.00	45.00	0.50	4.00	7.00	990
46	57.25	53.75	51.00	40	1.62	Specified by purchaser	46.00	47.12	0.50	4.06	7.31	1060
48	59.50	56.00	53.50	44	1.62	Specified by purchaser	48.00	49.12	0.50	4.25	7.56	1185
50	61.75	58.25	55.50	44	1.88	Specified by purchaser	50.00	51.25	0.50	4.38	8.00	1270
52	64.00	60.50	57.50	44	1.88	Specified by purchaser	52.00	53.25	0.50	4.56	8.25	1410
54	66.25	62.75	59.50	44	1.88	Specified by purchaser	54.00	55.25	0.50	4.75	8.50	1585
56	68.75	65.00	62.00	48	1.88	Specified by purchaser	56.00	57.38	0.50	4.88	9.00	1760
58	71.00	67.25	64.00	48	1.88	Specified by purchaser	58.00	59.38	0.50	5.06	9.25	1915
60	73.00	69.25	66.00	52	1.88	Specified by purchaser	60.00	61.38	0.50	5.19	9.44	2045

(A) All dimensions are in inches

(B) These flanges will be furnished with a 1/16" raised face unless otherwise specified.

(C) Standard Bore will be furnished unless otherwise specified.

ASME B16.47 series A flange

▶ Class 300 Welding Neck Flanges

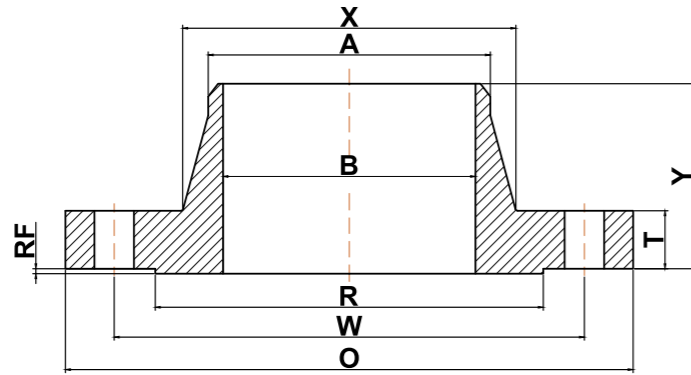

Nominal Pipe Size	Outside Diameter (O)	Bolt Circle (W)	Raised Face Diameter (R)	Number of Holes	Diameter of Holes	Bore (B)	Top of Hub (A)	Hub Diameter (X)	Minimum Fillet Radius (r)	Minimum Thickness (T)	Length Thru Hub (Y)	Approximate Weight (lbs)
26	38.25	34.50	29.50	28	1.75	Specified by purchaser	26.00	28.38	0.38	3.12	7.25	605
28	40.75	37.00	31.50	28	1.75	Specified by purchaser	28.00	30.50	0.44	3.38	7.75	745
30	43.00	39.25	33.75	28	1.88	Specified by purchaser	30.00	32.56	0.44	3.62	8.25	870
32	45.25	41.50	36.00	28	2.00	Specified by purchaser	32.00	34.69	0.44	3.88	8.75	1005
34	47.50	43.50	38.00	28	2.00	Specified by purchaser	34.00	36.88	0.50	4.00	9.12	1145
36	50.00	46.00	40.25	32	2.12	Specified by purchaser	36.00	39.00	0.50	4.12	9.50	1275
38	46.00	43.00	40.50	32	1.62	Specified by purchaser	38.00	39.12	0.50	4.25	7.12	695
40	48.75	45.50	42.75	32	1.75	Specified by purchaser	40.00	41.25	0.50	4.50	7.62	840
42	50.75	47.50	44.75	32	1.75	Specified by purchaser	42.00	43.25	0.50	4.69	7.88	950
44	53.25	49.75	47.00	32	1.88	Specified by purchaser	44.00	45.25	0.50	4.88	8.12	1055
46	55.75	52.00	49.00	28	2.00	Specified by purchaser	46.00	47.38	0.50	5.06	8.50	1235
48	57.75	54.00	51.25	32	2.00	Specified by purchaser	48.00	49.38	0.50	5.25	8.81	1380
50	60.25	56.25	53.50	32	2.12	Specified by purchaser	50.00	51.38	0.50	5.50	9.12	1530
52	62.25	58.25	55.50	32	2.12	Specified by purchaser	52.00	53.38	0.50	5.69	9.38	1660
54	65.25	61.00	57.75	28	2.38	Specified by purchaser	54.00	55.50	0.50	6.00	9.94	2050
56	67.25	63.00	59.75	28	2.38	Specified by purchaser	56.00	57.62	0.50	6.06	10.25	2155
58	69.25	65.00	62.00	32	2.38	Specified by purchaser	58.00	59.62	0.50	6.25	10.50	2270
60	71.25	67.00	64.00	32	2.38	Specified by purchaser	60.00	61.62	0.50	6.44	10.75	2470

(A) All dimensions are in inches

(B) These flanges will be furnished with a 1/16" raised face unless otherwise specified.

(C) Standard Bore will be furnished unless otherwise specified.

ASME B16.47 series A flange

▶ Class 400 Welding Neck Flanges

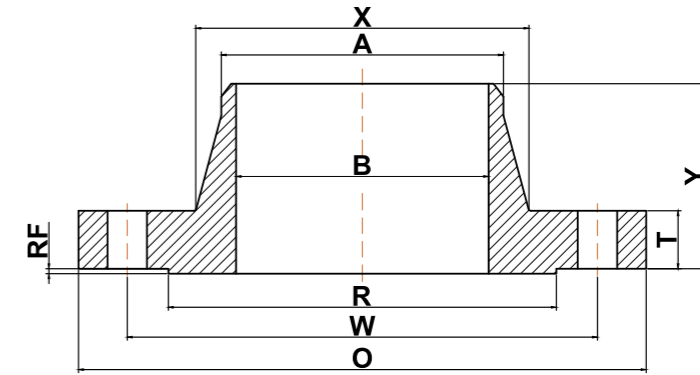

Nominal Pipe Size	Outside Diameter (O)	Bolt Circle (W)	Raised Face Diameter (R)	Number of Holes	Diameter of Holes	Bore (B)	Top of Hub (A)	Hub Diameter (X)	Minimum Fillet Radius (r)	Minimum Thickness (T)	Length Thru Hub (Y)	Approximate Weight (lbs)
26	38.25	34.50	29.50	28	1.88	Specified by purchaser	26.00	28.62	0.44	3.50	7.62	650
28	40.75	37.00	31.50	28	2.00	Specified by purchaser	28.00	30.81	0.50	3.75	8.12	785
30	43.00	39.25	33.75	28	2.12	Specified by purchaser	30.00	32.94	0.50	4.00	8.62	905
32	45.25	41.50	36.00	28	2.12	Specified by purchaser	32.00	35.00	0.50	4.25	9.12	1065
34	47.50	43.50	38.00	28	2.12	Specified by purchaser	34.00	37.19	0.56	4.38	9.50	1200
36	50.00	46.00	40.25	32	2.12	Specified by purchaser	36.00	39.38	0.56	4.50	9.88	1340
38	47.50	44.00	40.75	32	1.88	Specified by purchaser	38.00	39.50	0.56	4.88	8.12	935
40	50.00	46.25	43.00	32	2.00	Specified by purchaser	40.00	41.50	0.56	5.12	8.50	1090
42	52.00	48.25	45.00	32	2.00	Specified by purchaser	42.00	43.62	0.56	5.25	8.81	1190
44	54.50	50.50	47.25	32	2.12	Specified by purchaser	44.00	45.62	0.56	5.50	9.18	1375
46	56.75	52.75	49.50	36	2.12	Specified by purchaser	46.00	47.75	0.56	5.75	9.62	1525
48	59.50	55.25	51.50	28	2.38	Specified by purchaser	48.00	49.88	0.56	6.00	10.12	1790
50	61.75	57.50	53.62	32	2.38	Specified by purchaser	50.00	52.00	0.56	6.19	10.56	1950
52	63.75	59.50	55.62	32	2.38	Specified by purchaser	52.00	54.00	0.56	6.38	10.88	2125
54	67.00	62.25	57.88	28	2.62	Specified by purchaser	54.00	56.12	0.56	6.69	11.38	2565
56	69.00	64.25	60.12	32	2.62	Specified by purchaser	56.00	58.25	0.56	6.88	11.75	2710
58	71.00	66.25	62.12	32	2.62	Specified by purchaser	58.00	60.25	0.56	7.00	12.06	3230
60	74.25	69.00	64.38	32	2.88	Specified by purchaser	60.00	62.38	0.56	7.31	12.56	3820

(a) All dimensions are in inches

(b) These flanges will be furnished with a 1/4" raised face unless otherwise specified.

➡ ASME B16.47 series A flange

▶ Class 600 Welding Neck Flanges

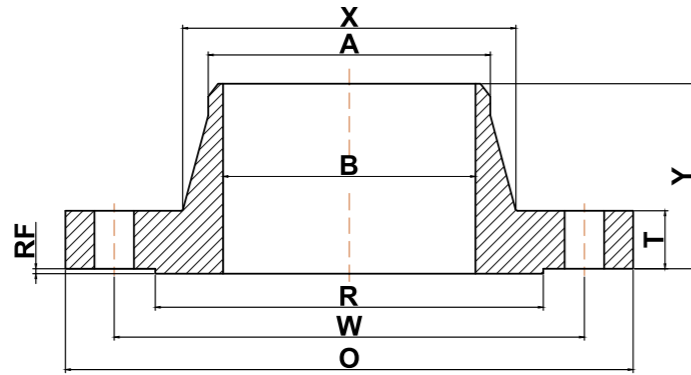

Nominal Pipe Size	Outside Diameter (O)	Bolt Circle (W)	Raised Face Diameter (R)	Number of Holes	Diameter of Holes	Bore (B)	Top of Hub (A)	Hub Diameter (X)	Minimum Fillet Radius (r)	Minimum Thickness (T)	Length Thru Hub (Y)	Approximate Weight (lbs)
26	40.00	36.00	29.50	28	2.00	Specified by purchaser	26.00	29.44	0.50	4.25	8.75	940
28	42.25	38.00	31.50	28	2.12	Specified by purchaser	28.00	31.62	0.50	4.38	9.25	1060
30	44.50	40.25	33.75	28	2.12	Specified by purchaser	30.00	33.94	0.50	4.50	9.75	1210
32	47.00	42.50	36.00	28	2.38	Specified by purchaser	32.00	36.12	0.50	4.62	10.25	1375
34	49.00	44.50	38.00	28	2.38	Specified by purchaser	34.00	38.31	0.56	4.75	10.62	1540
36	51.75	47.00	40.25	28	2.62	Specified by purchaser	36.00	40.62	0.56	4.88	11.12	1705
38	50.00	45.75	41.50	28	2.38	Specified by purchaser	38.00	40.25	0.56	6.00	10.00	1470
40	52.00	47.75	43.75	32	2.38	Specified by purchaser	40.00	42.25	0.56	6.25	10.38	1630
42	55.25	50.50	46.00	28	2.62	Specified by purchaser	42.00	44.38	0.56	6.62	11.00	2030
44	57.25	52.50	48.25	32	2.62	Specified by purchaser	44.00	46.50	0.56	6.81	11.38	2160
46	59.50	54.75	50.25	32	2.62	Specified by purchaser	46.00	48.62	0.56	7.06	11.81	2410
48	62.75	57.50	52.50	32	2.88	Specified by purchaser	48.00	50.75	0.56	7.44	12.44	2855
50	65.75	60.00	54.50	28	3.12	Specified by purchaser	50.00	52.88	0.56	7.75	12.94	3330
52	67.75	62.00	56.50	32	3.12	Specified by purchaser	52.00	54.88	0.56	8.00	13.25	3560
54	70.00	64.25	58.75	32	3.12	Specified by purchaser	54.00	57.00	0.56	8.25	13.75	3920
56	73.00	66.75	60.75	32	3.38	Specified by purchaser	56.00	59.12	0.62	8.56	14.25	4280
58	75.00	68.75	63.00	32	3.38	Specified by purchaser	58.00	61.12	0.62	8.75	14.56	4640
60	78.50	71.75	65.25	28	3.62	Specified by purchaser	60.00	63.38	0.69	9.19	15.31	5000

(a) All dimensions are in inches

(b) These flanges will be furnished with a 1/4" raised face unless otherwise specified.

➡ ASME B16.47 series A flange

▶ Class 900 Welding Neck Flanges

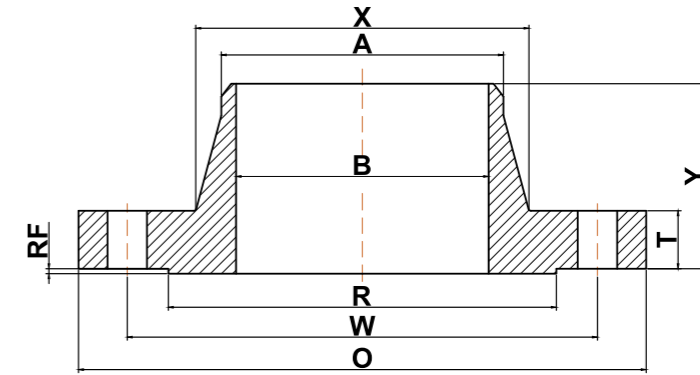

Nominal Pipe Size	Outside Diameter (O)	Bolt Circle (W)	Raised Face Diameter (R)	Number of Holes	Diameter of Holes	Bore (B)	Top of Hub (A)	Hub Diameter (X)	Minimum Fillet Radius (r)	Minimum Thickness (T)	Length Thru Hub (Y)	Approximate Weight (lbs)
26	42.75	37.50	29.50	20	2.88	Specified by purchaser	26.00	30.50	0.44	5.50	11.25	1525
28	46.00	40.25	31.50	20	3.12	Specified by purchaser	28.00	32.75	0.50	5.62	11.75	1810
30	48.50	42.75	33.75	20	3.12	Specified by purchaser	30.00	35.00	0.50	5.88	12.25	2120
32	51.75	45.50	36.00	20	3.38	Specified by purchaser	32.00	37.25	0.50	6.25	13.00	2545
34	55.00	48.25	38.00	20	3.62	Specified by purchaser	34.00	39.62	0.56	6.50	13.75	2970
36	57.50	50.75	40.25	20	3.62	Specified by purchaser	36.00	41.88	0.56	6.75	14.25	3395
38	57.50	50.75	43.25	20	3.62	Specified by purchaser	38.00	42.25	0.75	7.50	13.88	3385
40	59.50	52.75	45.75	24	3.62	Specified by purchaser	40.00	44.38	0.81	7.75	14.31	3620
42	61.50	54.75	47.75	24	3.62	Specified by purchaser	42.00	46.31	0.81	8.12	14.62	3960
44	64.88	57.62	50.00	24	3.88	Specified by purchaser	44.00	48.62	0.88	8.44	15.38	4300
46	68.25	60.50	52.50	24	4.12	Specified by purchaser	46.00	50.88	0.88	8.88	16.18	4640
48	70.25	62.50	54.50	24	4.12	Specified by purchaser	48.00	52.88	0.94	9.19	16.50	4980

(a) All dimensions are in inches

(b) These flanges will be furnished with a 1/4" raised face unless otherwise specified.

ASME B16.47 series A flange

ASME B16.47 series A flange

Class 150 Blind Flanges

Blind Flanges

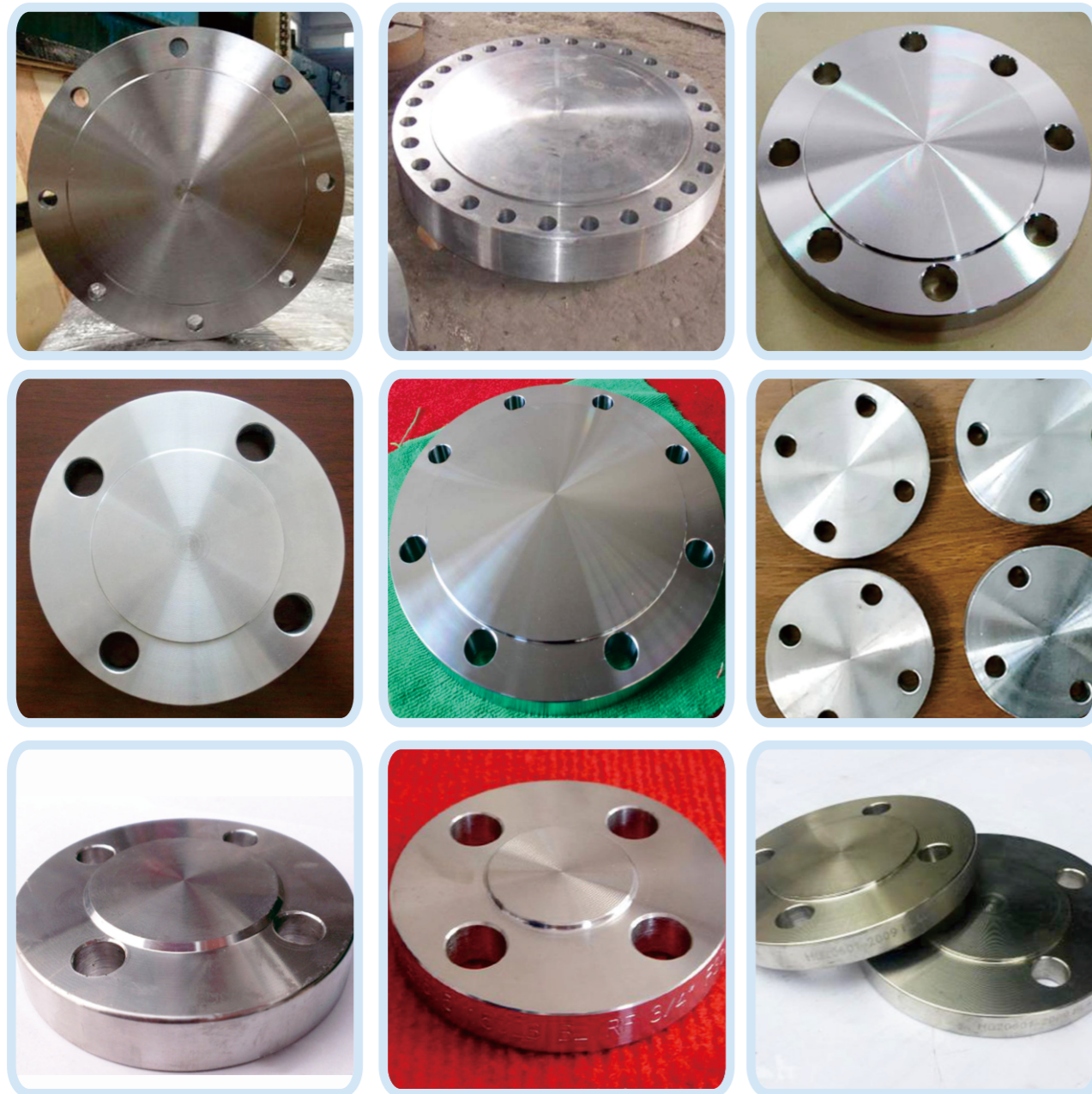
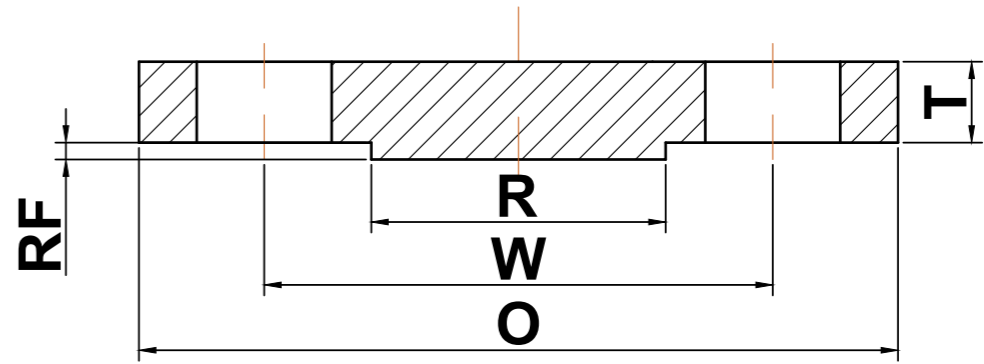

Nominal Pipe Size	Outside Diameter (O)	Bolt Circle (W)	Raised Face Diameter (R)	Number of Holes	Diameter of Holes	Minimum Thickness (T)	Approximate Weight (lbs)
26	34.25	31.75	29.50	24	1.38	2.69	702
28	36.50	34.00	31.50	28	1.38	2.81	833
30	38.75	36.00	33.75	28	1.38	2.94	982
32	41.75	38.50	36.00	28	1.62	3.19	1238
34	43.75	40.50	38.00	32	1.62	3.25	1384
36	46.00	42.75	40.25	32	1.62	3.56	1676
38	48.75	45.25	42.25	32	1.62	3.44	1819
40	50.75	47.25	44.25	36	1.62	3.56	2040
42	53.00	49.50	47.00	36	1.62	3.81	2380
44	55.25	51.75	49.00	40	1.62	4.00	2715
46	57.25	53.75	51.00	40	1.62	4.06	2961
48	59.50	56.00	53.50	44	1.62	4.25	3350
50	61.75	58.25	55.50	44	1.88	4.38	3716
52	64.00	60.50	57.50	44	1.88	4.56	4156
54	66.25	62.75	59.50	44	1.88	4.75	4639
56	68.75	65.00	62.00	48	1.88	4.88	5130
58	71.00	67.25	64.00	48	1.88	5.06	5675
60	73.00	69.25	66.00	52	1.88	5.19	6155

(a) All dimensions are in inches

(b) These flanges will be furnished with a 1/16" raised face unless otherwise specified.

ASME B16.47 series A flange

▶ Class 300 Blind Flanges

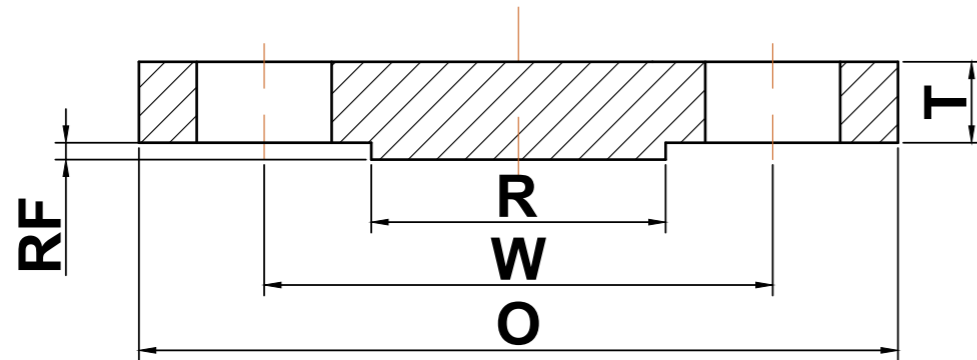

Nominal Pipe Size	Outside Diameter (O)	Bolt Circle (W)	Raised Face Diameter (R)	Number of Holes	Diameter of Holes	Thickness (T)	Approximate Weight (lbs)
26	38.25	34.50	29.50	28	1.75	3.31	1079
28	40.75	37.00	31.50	28	1.75	3.56	1315
30	43.00	39.25	33.75	28	1.88	3.75	1545
32	45.25	41.50	36.00	28	2.00	3.94	1795
34	47.50	43.50	38.00	28	2.00	4.12	2068
36	50.00	46.00	40.25	32	2.12	4.38	2435
38	46.00	43.00	40.50	32	1.62	4.25	2001
40	48.75	45.50	42.75	32	1.75	4.50	2380
42	50.75	47.50	44.75	32	1.75	4.69	2689
44	53.25	49.75	47.00	32	1.88	4.88	3079
46	55.75	52.00	49.00	28	2.00	5.06	3500
48	57.75	54.00	51.25	32	2.00	5.25	3896
50	60.25	56.25	53.50	32	2.12	5.50	4442
52	62.25	58.25	55.50	32	2.12	5.69	4906
54	65.25	61.00	57.75	28	2.38	6.00	5684
56	67.25	63.00	59.75	28	2.38	6.06	6099
58	69.25	65.00	62.00	32	2.38	6.25	6669
60	71.25	67.00	64.00	32	2.38	6.44	7274

(a) All dimensions are in inches

(b) These flanges will be furnished with a 1/16" raised face unless otherwise specified.

ASME B16.47 series A flange

▶ Class 400 Blind Flanges

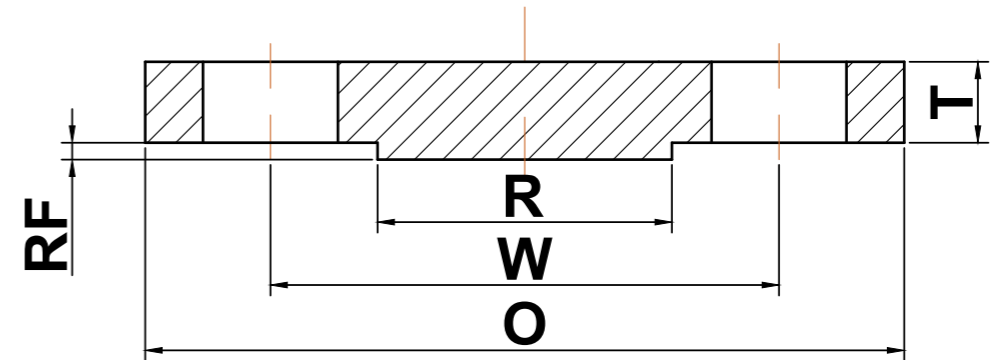

Nominal Pipe Size	Outside Diameter (O)	Bolt Circle (W)	Raised Face Diameter (R)	Number of Holes	Diameter of Holes	Minimum Thickness (T)	Approximate Weight (lbs)
26	38.25	34.50	29.50	28	1.88	3.88	1263
28	40.75	37.00	31.50	28	2.00	4.12	1520
30	43.00	39.25	33.75	28	2.12	4.38	1802
32	45.25	41.50	36.00	28	2.12	4.56	2075
34	47.50	43.50	38.00	28	2.12	4.81	2415
36	50.00	46.00	40.25	32	2.12	5.06	2815
38	47.50	44.00	40.75	32	1.88	4.88	2450
40	50.00	46.25	43.00	32	2.00	5.12	2849
42	52.00	48.25	45.00	32	2.00	5.25	3160
44	54.50	50.50	47.25	32	2.12	5.50	3635
46	56.75	52.75	49.50	36	2.12	5.75	4120
48	59.50	55.25	51.50	28	2.38	6.00	4725
50	61.75	57.50	53.62	32	2.38	6.25	5303
52	63.75	59.50	55.62	32	2.38	6.44	5823
54	67.00	62.25	57.88	28	2.62	6.75	6742
56	69.00	64.25	60.12	32	2.62	6.94	7352
58	71.00	66.25	62.12	32	2.62	7.12	7986
60	74.25	69.00	64.38	32	2.88	7.44	9126

(a) All dimensions are in inches

(b) These flanges will be furnished with a 1/4" raised face unless otherwise specified.

➡ ASME B16.47 series A flange

▶ Class 600 Blind Flanges

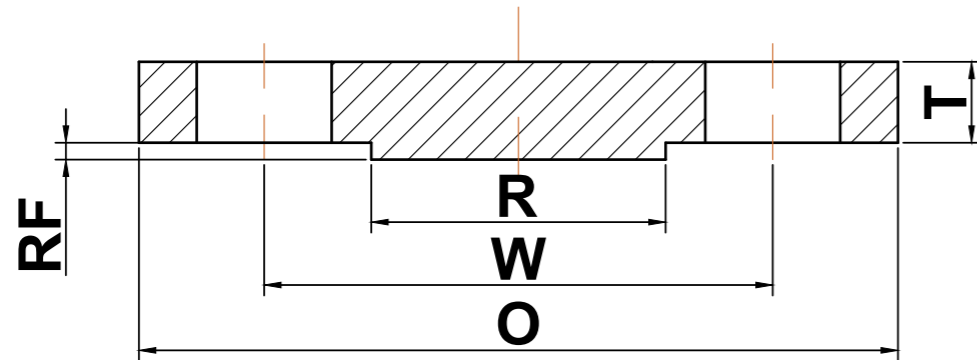

Nominal Pipe Size	Outside Diameter (O)	Bolt Circle (W)	Raised Face Diameter (R)	Number of Holes	Diameter of Holes	Minimum Thickness (T)	Approximate Weight (lbs)
26	40.00	36.00	29.50	28	2.00	4.94	1760
28	42.25	38.00	31.50	28	2.12	5.19	2061
30	44.50	40.25	33.75	28	2.12	5.50	2423
32	47.00	42.50	36.00	28	2.38	5.81	2858
34	49.00	44.50	38.00	28	2.38	6.06	3237
36	51.75	47.00	40.25	28	2.62	6.38	3800
38	50.00	45.75	41.50	28	2.38	6.12	3405
40	52.00	47.75	43.75	32	2.38	6.38	3838
42	55.25	50.50	46.00	28	2.62	6.75	4585
44	57.25	52.50	48.25	32	2.62	7.00	5105
46	59.50	54.75	50.25	32	2.62	7.31	5758
48	62.75	57.50	52.50	32	2.88	7.69	6737
50	65.75	60.00	54.50	28	3.12	8.00	7695
52	67.75	62.00	56.50	32	3.12	8.25	8425
54	70.00	64.25	58.75	32	3.12	8.56	9333
56	73.00	66.75	60.75	32	3.38	8.88	10,530
58	75.00	68.75	63.00	32	3.38	9.12	11,414
60	78.50	71.75	65.25	28	3.62	9.56	13,108

(a) All dimensions are in inches

(b) These flanges will be furnished with a 1/16" raised face unless otherwise specified.

➡ ASME B16.47 series A flange

▶ Class 900 Blind Flanges

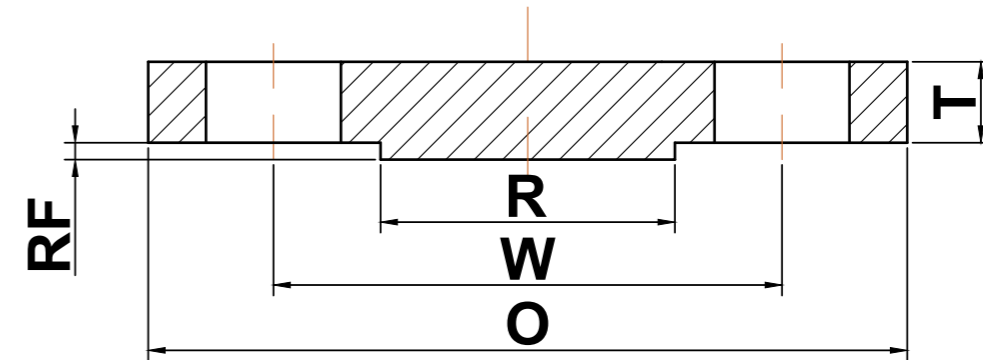

Nominal Pipe Size	Outside Diameter (O)	Bolt Circle (W)	Raised Face Diameter (R)	Number of Holes	Diameter of Holes	Minimum Thickness (T)	Approximate Weight (lbs)
26	42.75	37.50	29.50	20	2.88	6.31	2565
28	46.00	40.25	31.50	20	3.12	6.75	3178
30	48.50	42.75	33.75	20	3.12	7.18	3759
32	51.75	45.50	36.00	20	3.38	7.62	4541
34	55.00	48.25	38.00	20	3.62	8.06	5425
36	57.50	50.75	40.25	20	3.62	8.44	6210
38	57.50	50.75	43.25	20	3.62	8.50	6253
40	59.50	52.75	45.75	24	3.62	8.81	6940
42	61.50	54.75	47.75	24	3.62	9.12	7675
44	64.88	57.62	50.00	24	3.88	9.56	8955
46	68.25	60.50	52.50	24	4.12	10.06	10,426
48	70.25	62.50	54.50	24	4.12	10.38	11,398

(a) All dimensions are in inches

(b) These flanges will be furnished with a 1/4" raised face unless otherwise specified.

➔ ASME B16.47 series B flange

➔ ASME B16.47 series B flange

▶ Class 75 Welding Neck Flanges

Welding Neck Flanges

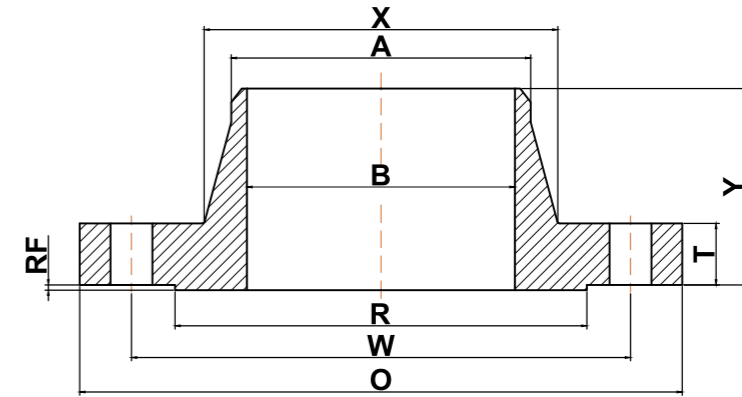

Nominal Pipe Size	Outside Diameter (O)	Bolt Circle (W)	Raised Face Diameter (R)	Number of Holes	Diameter of Holes	Bore (B)	Top of Hub (A)	Hub Diameter (X)	Minimum Fillet Radius (r)	Minimum Thickness (T)	Length Thru Hub (Y)	Approximate Weight (lbs)
26	30.00	28.50	27.75	36	0.75	Specified by purchaser	26.06	26.62	0.31	1.31	2.31	80
28	32.00	30.50	29.75	40	0.75	Specified by purchaser	28.06	28.62	0.31	1.31	2.44	85
30	34.00	32.50	31.75	44	0.75	Specified by purchaser	30.06	30.62	0.31	1.31	2.56	90
32	36.00	34.50	33.75	48	0.75	Specified by purchaser	32.06	32.62	0.31	1.38	2.75	105
34	38.00	36.50	35.75	52	0.75	Specified by purchaser	34.06	34.62	0.31	1.38	2.88	110
36	40.69	39.06	38.00	40	0.88	Specified by purchaser	36.06	36.81	0.38	1.44	3.38	145
38	42.69	41.06	40.00	40	0.88	Specified by purchaser	38.06	38.81	0.38	1.50	3.50	160
40	44.69	43.06	42.00	44	0.88	Specified by purchaser	40.06	40.81	0.38	1.50	3.62	170
42	46.69	45.06	44.00	48	0.88	Specified by purchaser	42.06	42.81	0.38	1.56	3.75	185
44	49.25	47.38	46.25	36	1.00	Specified by purchaser	44.06	44.88	0.38	1.69	4.12	230
46	51.25	49.38	48.25	40	1.00	Specified by purchaser	46.06	46.88	0.38	1.75	4.25	245
48	53.25	51.38	50.25	44	1.00	Specified by purchaser	48.06	48.88	0.38	1.81	4.38	270
50	55.25	53.38	52.25	44	1.00	Specified by purchaser	50.06	50.94	0.38	1.88	4.56	290
52	57.38	55.50	54.25	48	1.00	Specified by purchaser	52.06	52.94	0.38	1.88	4.75	310
54	59.38	57.50	56.25	48	1.00	Specified by purchaser	54.06	55.00	0.38	1.94	4.94	340
56	62.00	59.88	58.50	40	1.12	Specified by purchaser	56.06	57.12	0.44	2.00	5.31	400
58	64.00	61.88	60.50	44	1.12	Specified by purchaser	58.06	59.12	0.44	2.06	5.44	430
60	66.00	63.88	62.50	44	1.12	Specified by purchaser	60.06	61.12	0.44	2.19	5.69	475

(A) All dimensions are in inches

(B) These flanges will be furnished with a 1/16" raised face unless otherwise specified.

(C) Standard Bore will be furnished unless otherwise specified.

ASME B16.47 series B flange

▶ Class 150 Welding Neck Flanges

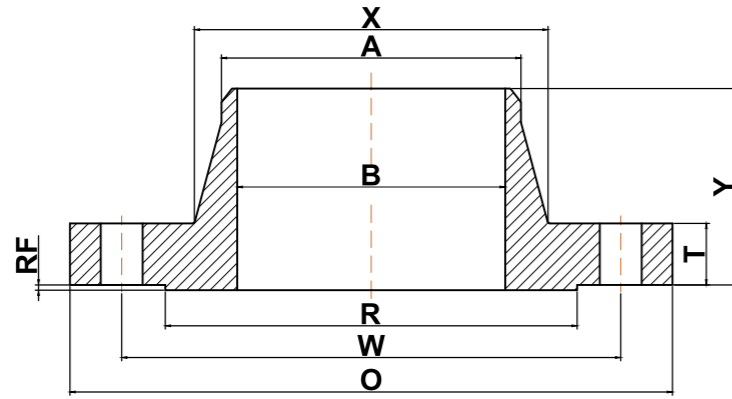

Nominal Pipe Size	Outside Diameter (O)	Bolt Circle (W)	Raised Face Diameter (R)	Number of Holes	Diameter of Holes	Bore (B)	Top of Hub (A)	Hub Diameter (X)	Minimum Fillet Radius (r)	Maximum Thickness (T)	Length Thru Hub (Y)	Approximate Weight (lbs)
26	30.94	29.31	28.00	36	0.88	Specified by purchaser	26.06	26.94	0.38	1.62	3.50	120
28	32.94	31.31	30.00	40	0.88	Specified by purchaser	28.06	28.94	0.38	1.75	3.75	140
30	34.94	33.31	32.00	44	0.88	Specified by purchaser	30.06	31.00	0.38	1.75	3.94	150
32	37.06	35.44	34.00	48	0.88	Specified by purchaser	32.06	33.06	0.38	1.81	4.25	170
34	39.56	37.69	36.25	40	1.00	Specified by purchaser	34.06	35.12	0.38	1.94	4.34	210
36	41.62	39.75	38.25	44	1.00	Specified by purchaser	36.06	37.19	0.38	2.06	4.62	240
38	44.25	42.12	40.25	40	1.12	Specified by purchaser	38.12	39.25	0.38	2.12	4.88	290
40	46.25	44.12	42.50	44	1.12	Specified by purchaser	40.12	41.31	0.38	2.19	5.06	310
42	48.25	46.12	44.50	48	1.12	Specified by purchaser	42.12	43.38	0.44	2.31	5.25	345
44	50.25	48.12	46.50	52	1.12	Specified by purchaser	44.12	45.38	0.44	2.38	5.38	370
46	52.81	50.56	48.62	40	1.25	Specified by purchaser	46.12	47.44	0.44	2.44	5.69	435
48	54.81	52.56	50.75	44	1.25	Specified by purchaser	48.12	49.50	0.44	2.56	5.88	480
50	56.81	54.56	52.75	48	1.25	Specified by purchaser	50.12	51.50	0.44	2.69	6.06	520
52	58.81	56.56	54.75	52	1.25	Specified by purchaser	52.12	53.56	0.44	2.75	6.19	550
54	61.00	58.75	56.75	56	1.25	Specified by purchaser	54.12	55.62	0.44	2.81	6.38	620
56	63.00	60.75	58.75	60	1.25	Specified by purchaser	56.12	57.69	0.56	2.88	6.56	650
58	65.94	63.44	60.75	48	1.38	Specified by purchaser	58.12	59.69	0.56	2.94	6.88	780
60	67.94	65.44	63.00	52	1.38	Specified by purchaser	60.12	61.81	0.56	3.00	7.06	850

(A) All dimensions are in inches

(B) These flanges will be furnished with a 1/16" raised face unless otherwise specified.

(C) Standard Bore will be furnished unless otherwise specified.

ASME B16.47 series B flange

▶ Class 300 Welding Neck Flanges

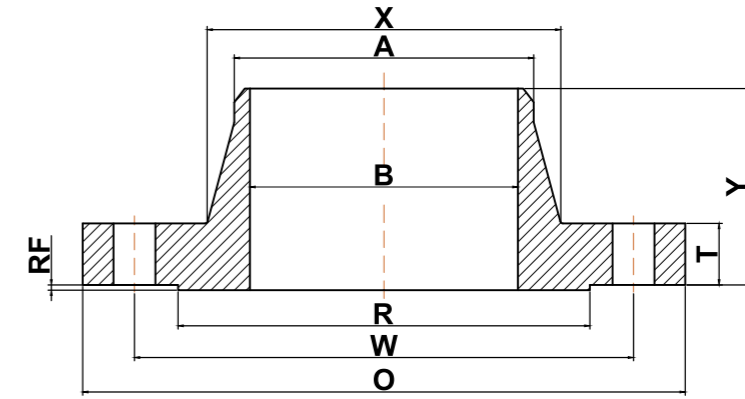

Nominal Pipe Size	Outside Diameter (O)	Bolt Circle (W)	Raised Face Diameter (R)	Number of Holes	Diameter of Holes	Bore (B)	Top of Hub (A)	Hub Diameter (X)	Minimum Fillet Radius (r)	Minimum Thickness (T)	Length Thru Hub (Y)	Approximate Weight (lbs)
26	34.12	31.62	29.00	32	1.38	Specified by purchaser	26.19	27.62	0.56	3.50	5.69	400
28	36.25	33.75	31.00	36	1.38	Specified by purchaser	28.19	29.75	0.56	3.50	5.88	450
30	39.00	36.25	33.25	36	1.50	Specified by purchaser	30.25	32.00	0.56	3.69	6.22	550
32	41.50	38.50	35.50	32	1.62	Specified by purchaser	32.25	34.00	0.62	4.06	6.62	685
34	43.62	40.62	37.50	36	1.62	Specified by purchaser	34.25	36.12	0.62	4.06	6.81	750
36	46.12	42.88	39.75	32	1.75	Specified by purchaser	36.25	38.00	0.62	4.06	7.12	840
38	48.12	44.88	41.75	36	1.75	Specified by purchaser	38.25	40.00	0.62	4.38	7.56	915
40	50.12	46.88	43.88	40	1.75	Specified by purchaser	40.25	42.00	0.62	4.56	7.81	990
42	52.50	49.00	46.00	36	1.88	Specified by purchaser	42.31	44.00	0.62	4.69	8.06	1135
44	54.50	51.00	48.00	40	1.88	Specified by purchaser	44.31	46.19	0.62	5.00	8.44	1235
46	57.50	53.75	50.00	36	2.00	Specified by purchaser	46.31	48.38	0.62	5.06	8.75	1470
48	59.50	55.75	52.25	40	2.00	Specified by purchaser	48.31	50.31	0.62	5.06	8.81	1575
50	61.50	57.75	54.25	44	2.00	Specified by purchaser	50.31	52.38	0.62	5.44	9.25	1710
52	63.50	59.75	56.25	48	2.00	Specified by purchaser	52.31	54.44	0.62	5.62	9.56	1840
54	65.88	62.12	58.25	48	2.00	Specified by purchaser	54.31	56.50	0.62	5.38	9.44	1980
56	69.50	65.00	60.50	36	2.38	Specified by purchaser	56.31	58.81	0.69	6.06	10.56	2595
58	71.94	67.44	62.75	40	2.38	Specified by purchaser	58.31	60.94	0.69	6.06	10.81	2770
60	73.94	69.44	65.00	40	2.38	Specified by purchaser	60.31	62.94	0.69	5.94	10.69	2870

(A) All dimensions are in inches

(B) These flanges will be furnished with a 1/16" raised face unless otherwise specified.

(C) Standard Bore will be furnished unless otherwise specified.

➡ ASME B16.47 series B flange

▶ Class 400 Welding Neck Flanges

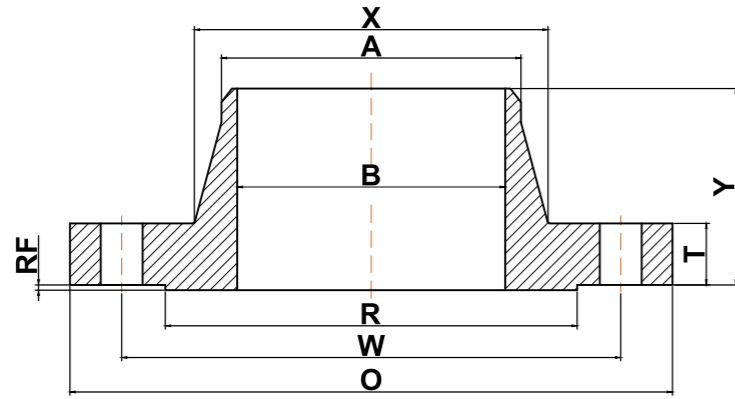

Nominal Pipe Size	Outside Diameter (O)	Bolt Circle (W)	Raised Face Diameter (R)	Number of Holes	Diameter of Holes	Bore (B)	Top of Hub (A)	Hub Diameter (X)	Minimum Fillet Radius (r)	Minimum Thickness (T)	Length Thru Hub (Y)	Approximate Weight (lbs)
26	33.50	30.75	28.00	28	1.50	Specified by purchaser	26.00	27.12	0.44	3.50	5.88	360
28	36.00	33.00	30.00	24	1.62	Specified by purchaser	28.00	29.12	0.50	3.75	6.25	450
30	38.25	35.25	32.25	28	1.62	Specified by purchaser	30.00	31.25	0.50	4.00	6.69	530
32	40.75	37.50	34.38	28	1.75	Specified by purchaser	32.00	33.25	0.50	4.25	7.06	635
34	42.75	39.50	36.50	32	1.75	Specified by purchaser	34.00	35.38	0.56	4.38	7.38	690
36	45.50	42.00	38.62	28	1.88	Specified by purchaser	36.00	37.50	0.56	4.69	7.88	855
38	47.50	44.00	40.75	32	1.88	Specified by purchaser	38.00	39.50	0.56	4.88	8.12	935
40	50.00	46.25	43.00	32	2.00	Specified by purchaser	40.00	41.50	0.56	5.12	8.50	1090
42	52.00	48.25	45.00	32	2.00	Specified by purchaser	42.00	43.62	0.56	5.25	8.81	1190
44	54.50	50.50	47.25	32	2.12	Specified by purchaser	44.00	45.62	0.56	5.50	9.18	1375
46	56.75	52.75	49.50	36	2.12	Specified by purchaser	46.00	47.75	0.56	5.75	9.62	1525
48	59.50	55.25	51.50	28	2.38	Specified by purchaser	48.00	49.88	0.56	6.00	10.12	1790
50	61.75	57.50	53.62	32	2.38	Specified by purchaser	50.00	52.00	0.56	6.19	10.56	1950
52	63.75	59.50	55.62	32	2.38	Specified by purchaser	52.00	54.00	0.56	6.38	10.88	2125
54	67.00	62.25	57.88	28	2.62	Specified by purchaser	54.00	56.12	0.56	6.69	11.38	2565
56	69.00	64.25	60.12	32	2.62	Specified by purchaser	56.00	58.25	0.56	6.88	11.75	2710
58	71.00	66.25	62.12	32	2.62	Specified by purchaser	58.00	60.25	0.56	7.00	12.06	3230
60	74.25	69.00	64.38	32	2.88	Specified by purchaser	60.00	62.38	0.56	7.31	12.56	3820

(a) All dimensions are in inches

(b) These flanges will be furnished with a 1/4" raised face unless otherwise specified.

➡ ASME B16.47 series B flange

▶ Class 600 Welding Neck Flanges

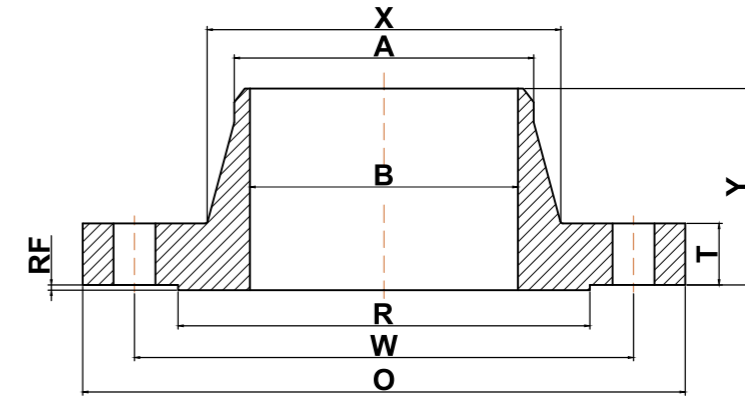

Nominal Pipe Size	Outside Diameter (O)	Bolt Circle (W)	Raised Face Diameter (R)	Number of Holes	Diameter of Holes	Bore (B)	Top of Hub (A)	Hub Diameter (X)	Minimum Fillet Radius (r)	Minimum Thickness (T)	Length Thru Hub (Y)	Approximate Weight (lbs)
26	35.00	31.75	28.62	28	1.75	Specified by purchaser	26.00	27.50	0.50	4.38	7.12	550
28	37.50	34.00	30.88	28	1.88	Specified by purchaser	28.00	29.62	0.50	4.56	7.50	650
30	40.25	36.50	33.12	28	2.00	Specified by purchaser	30.00	31.75	0.50	4.94	8.06	810
32	42.75	38.75	35.25	28	2.12	Specified by purchaser	32.00	33.88	0.50	5.12	8.50	950
34	45.75	41.50	37.50	24	2.38	Specified by purchaser	34.00	36.00	0.56	5.56	9.19	1205
36	47.75	43.50	39.75	28	2.38	Specified by purchaser	36.00	38.12	0.56	5.75	9.56	1340
38	50.00	45.75	41.50	28	2.38	Specified by purchaser	38.00	40.25	0.56	6.00	10.00	1470
40	52.00	47.75	43.75	32	2.38	Specified by purchaser	40.00	42.25	0.56	6.25	10.38	1630
42	55.25	50.50	46.00	28	2.62	Specified by purchaser	42.00	44.38	0.56	6.62	11.00	2030
44	57.25	52.50	48.25	32	2.62	Specified by purchaser	44.00	46.50	0.56	6.81	11.38	2160
46	59.50	54.75	50.25	32	2.62	Specified by purchaser	46.00	48.62	0.56	7.06	11.81	2410
48	62.75	57.50	52.50	32	2.88	Specified by purchaser	48.00	50.75	0.56	7.44	12.44	2855
50	65.75	60.00	54.50	28	3.12	Specified by purchaser	50.00	52.88	0.56	7.75	12.94	3330
52	67.75	62.00	56.50	32	3.12	Specified by purchaser	52.00	54.88	0.56	8.00	13.25	3560
54	70.00	64.25	58.75	32	3.12	Specified by purchaser	54.00	57.00	0.56	8.25	13.75	3920
56	73.00	66.75	60.75	32	3.38	Specified by purchaser	56.00	59.12	0.62	8.56	14.25	4280
58	75.00	68.75	63.00	32	3.38	Specified by purchaser	58.00	61.12	0.62	8.75	14.56	4640
60	78.50	71.75	65.25	28	3.62	Specified by purchaser	60.00	63.38	0.69	9.19	15.31	5000

(a) All dimensions are in inches

(b) These flanges will be furnished with a 1/4" raised face unless otherwise specified.

➡ ASME B16.47 series B flange

▶ Class 900 Welding Neck Flanges

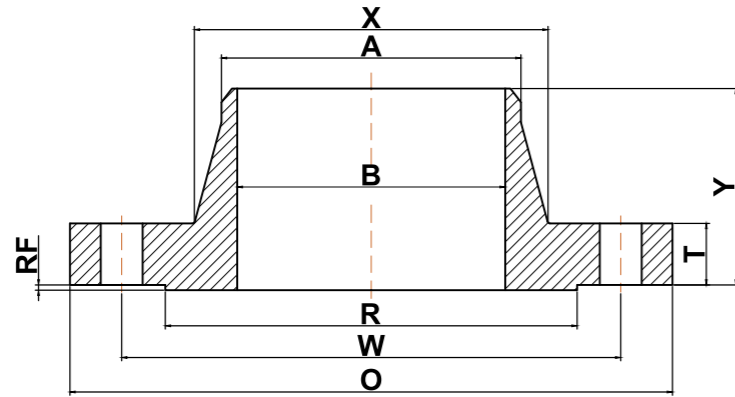

Nominal Pipe Size	Outside Diameter (O)	Bolt Circle (W)	Raised Face Diameter (R)	Number of Holes	Diameter of Holes	Bore (B)	Top of Hub (A)	Hub Diameter (X)	Minimum Fillet Radius (r)	Minimum Thickness (T)	Length Thru Hub (Y)	Approximate Weight (lbs)
26	40.25	35.50	30.00	20	2.62	Specified by purchaser	26.00	29.25	0.44	5.31	10.19	1050
28	43.50	38.25	32.25	20	2.88	Specified by purchaser	28.00	31.38	0.50	5.81	10.88	1520
30	46.50	40.75	34.50	20	3.12	Specified by purchaser	30.00	33.50	0.50	6.12	11.38	1820
32	48.75	43.00	36.50	20	3.12	Specified by purchaser	32.00	35.75	0.50	6.31	11.94	2065
34	51.75	45.50	39.00	20	3.38	Specified by purchaser	34.00	37.88	0.56	6.75	12.56	2450
36	53.00	47.25	40.50	24	3.12	Specified by purchaser	36.00	40.00	0.56	6.81	12.81	2520
38	57.50	50.75	43.25	20	3.62	Specified by purchaser	38.00	42.25	0.75	7.50	13.88	3385
40	59.50	52.75	45.75	24	3.62	Specified by purchaser	40.00	44.38	0.81	7.75	14.31	3620
42	61.50	54.75	47.75	24	3.62	Specified by purchaser	42.00	46.31	0.81	8.12	14.62	3960
44	64.88	57.62	50.00	24	3.88	Specified by purchaser	44.00	48.62	0.88	8.44	15.38	4300
46	68.25	60.50	52.50	24	4.12	Specified by purchaser	46.00	50.88	0.88	8.88	16.18	4640
48	70.25	62.50	54.50	24	4.12	Specified by purchaser	48.00	52.88	0.94	9.19	16.50	4980

(a) All dimensions are in inches

(b) These flanges will be furnished with a 1/4" raised face unless otherwise specified.

➡ ASME B16.47 series B flange

Blind Flanges

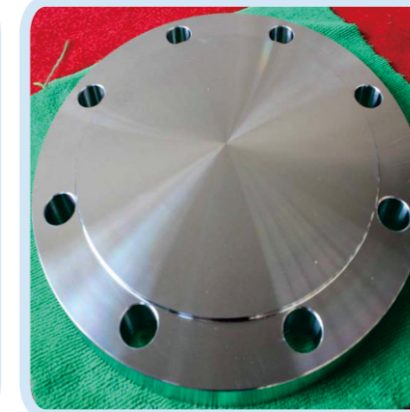
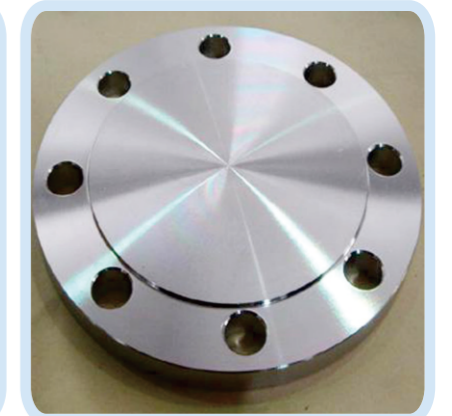
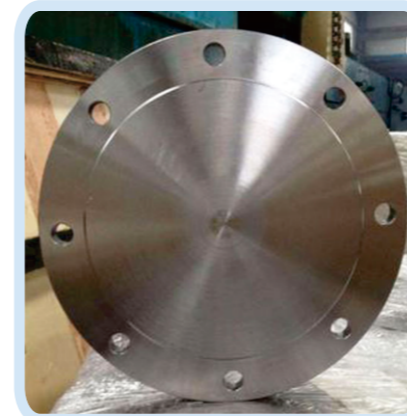

➡ ANSI B16.47 series B flange

▶ Class 75 Blind Flanges

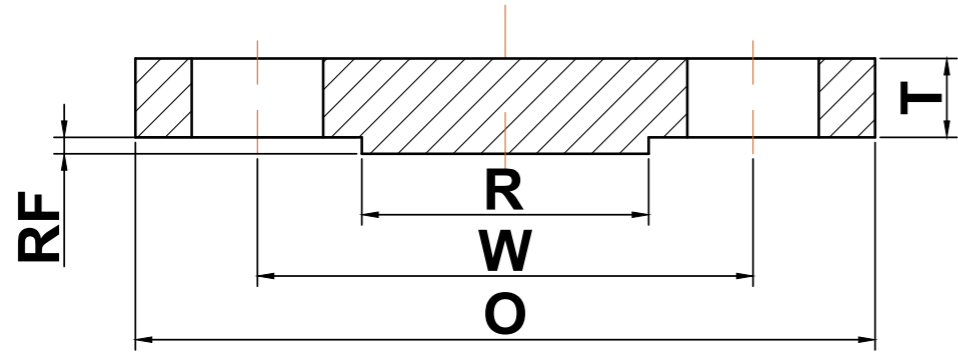

Nominal Pipe Size	Outside Diameter (O)	Bolt Circle (W)	Raised Face Diameter (R)	Number of Holes	Diameter of Holes	Minimum Thickness (T)	Approximate Weight (lbs)
26	30.00	28.50	27.75	36	0.75	1.31	255
28	32.00	30.50	29.75	40	0.75	1.31	290
30	34.00	32.50	31.75	44	0.75	1.31	330
32	36.00	34.50	33.75	48	0.75	1.44	390
34	38.00	36.50	35.75	52	0.75	1.50	430
36	40.69	39.06	38.00	40	0.88	1.67	520
38	42.69	41.06	40.00	40	0.88	1.75	595
40	44.69	43.06	42.00	44	0.88	1.75	760
42	46.69	45.06	44.00	48	0.88	1.88	895
44	49.25	47.38	46.25	36	1.00	1.94	1065
46	51.25	49.38	48.25	40	1.00	2.00	1185
48	53.25	51.38	50.25	44	1.00	2.12	1315
50	55.25	53.38	52.25	44	1.00	2.18	1505
52	57.38	55.50	54.25	48	1.00	2.25	1665
54	59.38	57.50	56.25	48	1.00	2.38	1840
56	62.00	59.88	58.50	40	1.12	2.44	2111
58	64.00	61.88	60.50	44	1.12	2.50	2300
60	66.00	63.88	62.50	44	1.12	2.62	2500

(a) All dimensions are in inches

(b) These flanges will be furnished with a 1/16" raised face unless otherwise specified.

➡ ANSI B16.47 series B flange

▶ Class 150 Blind Flanges

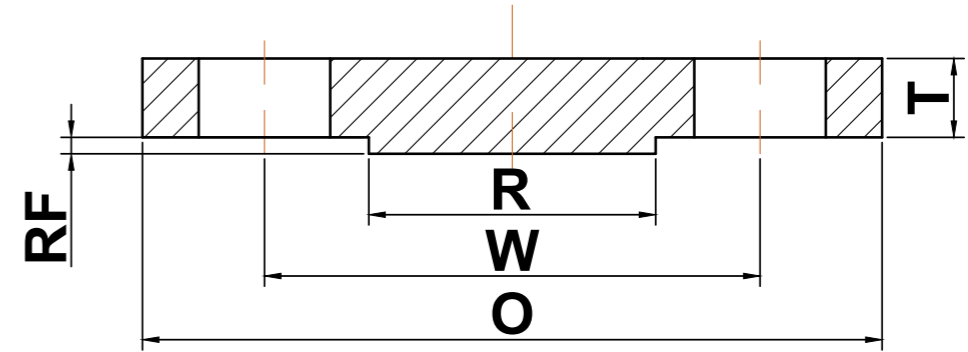

Nominal Pipe Size	Outside Diameter (O)	Bolt Circle (W)	Raised Face Diameter (R)	Number of Holes	Diameter of Holes	Maximum Thickness (T)	Approximate Weight (lbs)
26	30.94	29.31	28.00	36	0.88	1.75	375
28	32.94	31.31	30.00	40	0.88	1.88	455
30	34.94	33.31	32.00	44	0.88	2.00	545
32	37.06	35.44	34.00	48	0.88	2.12	648
34	39.56	37.69	36.25	40	1.00	2.25	782
36	41.62	39.75	38.25	44	1.00	2.31	890
38	44.25	42.12	40.25	40	1.12	2.50	1090
40	46.25	44.12	42.50	44	1.12	2.62	1247
42	48.25	46.12	44.50	48	1.12	2.69	1393
44	50.25	48.12	46.50	52	1.12	2.81	1579
46	52.81	50.56	48.62	40	1.25	2.94	1825
48	54.81	52.56	50.75	44	1.25	3.06	2045
50	56.81	54.56	52.75	48	1.25	3.18	2284
52	58.81	56.56	54.75	52	1.25	3.31	2547
54	61.00	58.75	56.75	56	1.25	3.44	2848
56	63.00	60.75	58.75	60	1.25	3.56	3145
58	65.94	63.44	60.75	48	1.38	3.68	3560
60	67.94	65.44	63.00	52	1.38	3.81	3913

(a) All dimensions are in inches

(b) These flanges will be furnished with a 1/16" raised face unless otherwise specified.

ASME B16.47 series B flange

▶ Class 300 Blind Flanges

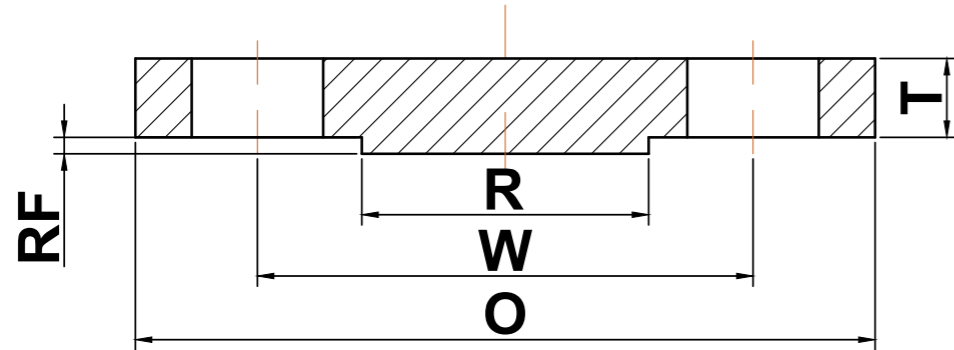

Nominal Pipe Size	Outside Diameter (O)	Bolt Circle (W)	Raised Face Diameter (R)	Number of Holes	Diameter of Holes	Minimum Thickness (T)	Approximate Weight (lbs)
26	34.12	31.62	29.00	32	1.38	3.50	905
28	36.25	33.75	31.00	36	1.38	3.50	1023
30	39.00	36.25	33.25	36	1.50	3.69	1250
32	41.50	38.50	35.50	32	1.62	4.06	1556
34	43.62	40.62	37.50	36	1.62	4.06	1719
36	46.12	42.88	39.75	32	1.75	4.06	1920
38	48.12	44.88	41.75	36	1.75	4.38	2257
40	50.12	46.88	43.88	40	1.75	4.56	2550
42	52.50	49.00	46.00	36	1.88	4.69	2875
44	54.50	51.00	48.00	40	1.88	5.00	3305
46	57.50	53.75	50.00	36	2.00	5.12	3766
48	59.50	55.75	52.25	40	2.00	5.31	4183
50	61.50	57.75	54.25	44	2.00	5.50	4629
52	63.50	59.75	56.25	48	2.00	5.68	5096
54	65.88	62.12	58.25	48	2.00	5.88	5679
56	69.50	65.00	60.50	36	2.38	6.18	6642
58	71.94	67.44	62.75	40	2.38	6.38	7347
60	73.94	69.44	65.00	40	2.38	6.56	7980

(a) All dimensions are in inches

(b) These flanges will be furnished with a 1/16" raised face unless otherwise specified.

ASME B16.47 series B flange

▶ Class 400 Blind Flanges

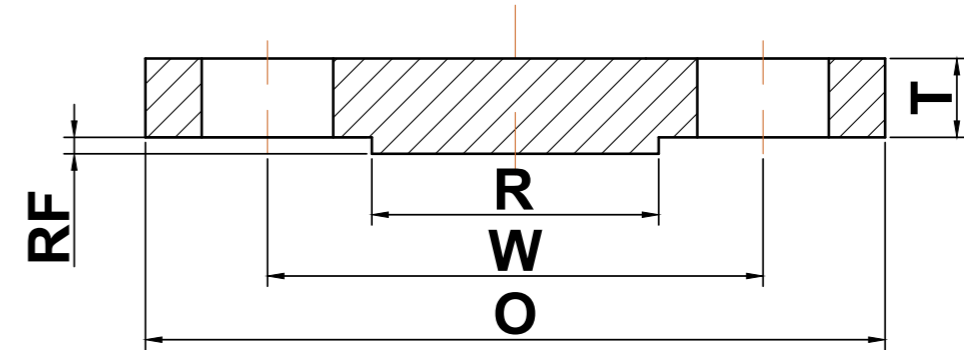

Nominal Pipe Size	Outside Diameter (O)	Bolt Circle (W)	Raised Face Diameter (R)	Number of Holes	Diameter of Holes	Minimum Thickness (T)	Approximate Weight (lbs)
26	33.50	30.75	28.00	28	1.50	3.50	875
28	36.00	33.00	30.00	24	1.62	3.75	1081
30	38.25	35.25	32.25	28	1.62	4.00	1302
32	40.75	37.50	34.38	28	1.75	4.25	1570
34	42.75	39.50	36.50	32	1.75	4.38	1780
36	45.50	42.00	38.62	28	1.88	4.69	2160
38	47.50	44.00	40.75	32	1.88	4.88	2450
40	50.00	46.25	43.00	32	2.00	5.12	2849
42	52.00	48.25	45.00	32	2.00	5.25	3160
44	54.50	50.50	47.25	32	2.12	5.50	3635
46	56.75	52.75	49.50	36	2.12	5.75	4120
48	59.50	55.25	51.50	28	2.38	6.00	4725
50	61.75	57.50	53.62	32	2.38	6.25	5303
52	63.75	59.50	55.62	32	2.38	6.44	5823
54	67.00	62.25	57.88	28	2.62	6.75	6742
56	69.00	64.25	60.12	32	2.62	6.94	7352
58	71.00	66.25	62.12	32	2.62	7.12	7986
60	74.25	69.00	64.38	32	2.88	7.44	9126

(a) All dimensions are in inches

(b) These flanges will be furnished with a 1/4" raised face unless otherwise specified.

➡ ASME B16.47 series B flange

▶ Class 600 Blind Flanges

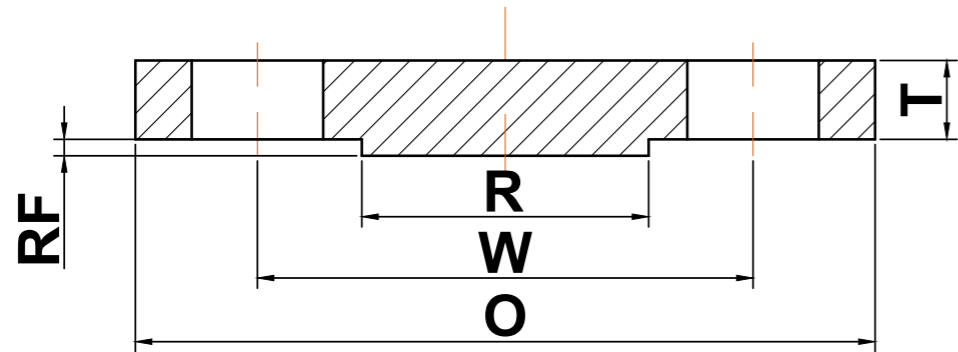

Nominal Pipe Size	Outside Diameter (O)	Bolt Circle (W)	Raised Face Diameter (R)	Number of Holes	Diameter of Holes	Minimum Thickness (T)	Approximate Weight (lbs)
26	35.00	31.75	28.62	28	1.75	4.38	1195
28	37.50	34.00	30.88	28	1.88	4.56	1427
30	40.25	36.50	33.12	28	2.00	5.00	1800
32	42.75	38.75	35.25	28	2.12	5.31	2160
34	45.75	41.50	37.50	24	2.38	5.68	2645
36	47.75	43.50	39.75	28	2.38	5.94	3013
38	50.00	45.75	41.50	28	2.38	6.12	3405
40	52.00	47.75	43.75	32	2.38	6.38	3838
42	55.25	50.50	46.00	28	2.62	6.75	4585
44	57.25	52.50	48.25	32	2.62	7.00	5105
46	59.50	54.75	50.25	32	2.62	7.31	5758
48	62.75	57.50	52.50	32	2.88	7.69	6737
50	65.75	60.00	54.50	28	3.12	8.00	7695
52	67.75	62.00	56.50	32	3.12	8.25	8425
54	70.00	64.25	58.75	32	3.12	8.56	9333
56	73.00	66.75	60.75	32	3.38	8.88	10,530
58	75.00	68.75	63.00	32	3.38	9.12	11,414
60	78.50	71.75	65.25	28	3.62	9.56	13,108

(a) All dimensions are in inches

(b) These flanges will be furnished with a 1/4" raised face unless otherwise specified.

➡ ASME B16.47 series B flange

▶ Class 900 Blind Flanges

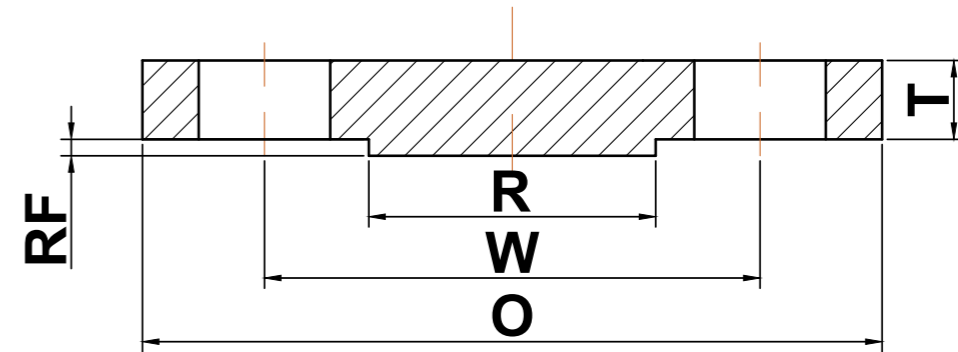

Nominal Pipe Size	Outside Diameter (O)	Bolt Circle (W)	Raised Face Diameter (R)	Number of Holes	Diameter of Holes	Minimum Thickness (T)	Approximate Weight (lbs)
26	40.25	35.50	30.00	20	2.62	6.06	2185
28	43.50	38.25	32.25	20	2.88	6.56	2762
30	46.50	40.75	34.50	20	3.12	6.93	3334
32	48.75	43.00	36.50	20	3.12	7.31	3865
34	51.75	45.50	39.00	20	3.38	7.68	4575
36	53.00	47.25	40.50	24	3.12	7.94	4963
38	57.50	50.75	43.25	20	3.62	8.50	6253
40	59.50	52.75	45.75	24	3.62	8.81	6940
42	61.50	54.75	47.75	24	3.62	9.12	7675
44	64.88	57.62	50.00	24	3.88	9.56	8955
46	68.25	60.50	52.50	24	4.12	10.06	10,426
48	70.25	62.50	54.50	24	4.12	10.38	11,398

(a) All dimensions are in inches

(b) These flanges will be furnished with a 1/4" raised face unless otherwise specified.

➡ Wall Thickness

Nom pipe Size	OD	NOMINAL WALL THICKNESS												
		Sch10	Sch20	Sch30	STD Wall	Sch40	Sch60	EXT Hvy	Sch80	Sch100	Sch120	Sch140	Sch160	XX Hvy
1/2	0.840	0.083	0.109	0.109	...	0.147	0.147	0.188	0.294
3/4	1.050	0.083	0.113	0.113	...	0.154	0.154	0.219	0.308
1	1.315	0.109	0.133	0.133	...	0.179	0.179	0.250	0.358
1 1/4	1.660	0.109	0.140	0.140	...	0.191	0.191	0.250	0.382
1 1/2	1.900	0.109	0.145	0.145	...	0.200	0.200	0.281	0.400
2	2.375	0.109	0.154	0.154	...	0.218	0.218	0.344	0.436
2 1/2	2.875	0.120	0.203	0.203	...	0.276	0.276	0.375	0.552
3	3.500	0.120	0.216	0.216	...	0.300	0.300	0.438	0.600
3 1/2	4.000	0.120	0.226	0.226	...	0.318	0.318	0.636
4	4.500	0.120	0.237	0.237	...	0.337	0.337	...	0.438	...	0.531	0.674
5	5.563	0.134	0.258	0.258	...	0.375	0.375	...	0.500	...	0.625	0.750
6	6.625	0.134	0.280	0.280	...	0.432	0.432	...	0.562	...	0.719	0.864
8	8.625	0.148	0.250	0.277	0.322	0.322	0.406	0.500	0.500	0.594	0.719	0.812	0.906	0.875
10	10.750	0.165	0.250	0.307	0.365	0.365	0.500	0.500	0.594	0.719	0.844	1.000	1.125	1.000
12	12.750	0.180	0.250	0.330	0.375	0.406	0.562	0.500	0.688	0.844	1.000	1.125	1.312	1.000
14	14.000	0.250	0.312	0.375	0.375	0.438	0.594	0.500	0.750	0.938	1.094	1.250	1.406	...
16	16.000	0.250	0.312	0.375	0.375	0.500	0.656	0.500	0.844	1.031	1.219	1.438	1.594	...
18	18.000	0.250	0.312	0.438	0.375	0.562	0.750	0.500	0.938	1.156	1.375	1.562	1.781	...
20	20.000	0.250	0.375	0.500	0.375	0.594	0.812	0.500	1.031	1.281	1.500	1.750	1.969	...
22	22.000	0.250	0.375	0.500
24	24.000	0.250	0.375	0.562	0.375	0.688	0.969	0.500	1.219	1.531	1.812	2.062	2.344	...
26	26.000	0.375	0.500
30	30.000	0.312	0.500	0.625	0.375	0.500
36	36.000	0.312	0.500	0.625	0.375	0.750	...	0.500
40	40.000	0.375	0.500
42	42.000	0.375	0.500
48	48.000	0.375	0.500

dimensions are in inches

- (1) Light wall thicknesses are identical to stainless steel Schedule 10S in sizes through 12", and to Schedule 10 sizes 14" and larger
- (2) Standard wall thicknesses are identical to stainless steel Schedule 40S in sizes through 10"
- (3) Extra heavy wall thicknesses are identical to stainless steel schedule 80S in sizes through 8"
- (4) Other types, sizes, and thicknesses of flanges can be provided to meet application
- (5) Stocked and manufactured in carbon steel, stainless steel, and variety of other metals and alloys
- (6) Inside pipe diameters are provided on the following page

➡ Weld Neck Flange Bores

Nom pipe Size	OD	NOMINAL BORE													
		Sch10	Sch20	Sch30	STD Wall	Sch40	Sch60	EXT Hvy	Sch80	Sch100	Sch120	Sch140	Sch160	XX Hvy	
1/2	0.840	0.674	0.622	0.622	...	0.546	0.546	0.464	0.252	
3/4	1.050	0.884	0.824	0.824	...	0.742	0.742	0.612	0.434	
1	1.315	1.097	1.049	1.049	...	0.957	0.957	0.815	0.599	
1 1/4	1.660	1.442	1.380	1.380	...	1.278	1.278	1.160	0.896	
1 1/2	1.900	1.682	1.610	1.610	...	1.500	1.500	1.338	1.100	
2	2.375	2.157	2.067	2.067	...	1.939	1.939	1.687	1.503	
2 1/2	2.875	2.635	2.469	2.469	...	2.323	2.323	2.125	1.771	
3	3.500	3.260	3.068	3.068	...	2.900	2.900	2.624	2.300	
3 1/2	4.000	3.760	3.548	3.548	...	3.364	3.364	2.728	
4	4.500	4.260	4.026	4.026	...	3.826	3.826	...	3.624	...	3.438	3.152	
5	5.563	5.295	5.047	5.047	...	4.813	4.813	...	4.563	...	4.313	4.063	
6	6.625	6.357	6.065	6.065	...	5.761	5.761	...	5.501	...	5.187	4.897	
8	8.625	8.329	8.125	8.071	7.981	7.981	7.813	7.625	7.625	7.437	7.187	7.001	6.813	6.875	
10	10.750	10.420	10.250	10.136	10.020	10.020	9.750	9.750	9.562	9.312	9.062	8.750	8.500	8.750	
12	12.750	12.390	12.250	12.090	12.000	11.938	11.626	11.750	11.374	11.062	10.750	10.500	10.126	10.750	
14	14.000	13.500	13.376	13.250	13.250	13.124	12.812	13.000	12.500	12.124	11.812	11.500	11.188	...	
16	16.000	15.500	15.376	15.250	15.250	15.000	14.688	15.000	14.312	13.938	13.562	13.124	12.812	...	
18	18.000	17.500	17.376	17.124	17.250	16.876	16.500	17.000	16.124	15.688	15.250	14.876	14.438	...	
20	20.000	19.500	19.250	19.000	19.250	18.812	18.376	19.000	17.938	17.438	17.000	16.500	16.062	...	
22	22.000	21.500	21.250	21.000	
24	24.000	23.500	23.250	22.876	23.250	22.624	22.062	23.000	21.562	20.938	20.376	19.876	19.312	...	
26	26.000	25.250	25.000	
30	30.000	29.376	29.000	28.750	29.250	29.000	
36	36.000	35.376	35.000	34.750	35.250	34.500	...	35.000	
40	40.000	39.250	39.000	
42	42.000	41.250	41.000	
48	48.000	47.250	47.000	

dimensions are in inches

- (1) Source: ANSI B36.10
- (2) These dimensions are the same for inside pipe diameter. ALWAYS specify bore when ordering
- (3) Other type, sizes, and thicknesses of flanges can be provided to meet application
- (4) Stocked and manufactured in carbon steel, stainless steel, and a variety of other metals and alloys
- (5) Wall thicknesses are provided on the previous page

Alternate Flange Facings

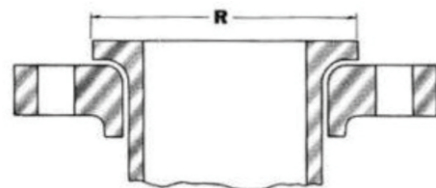

Lap-Joint

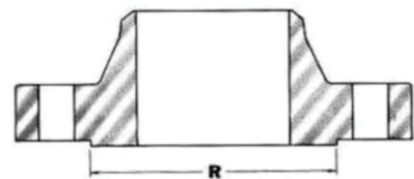

Raised-Face

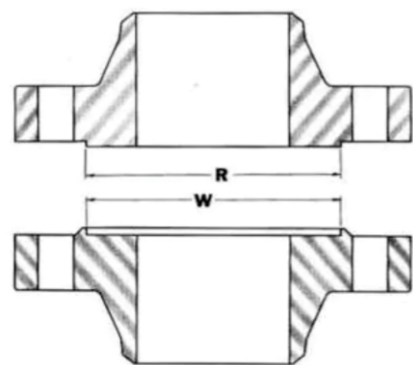

Large-Male-and-Female

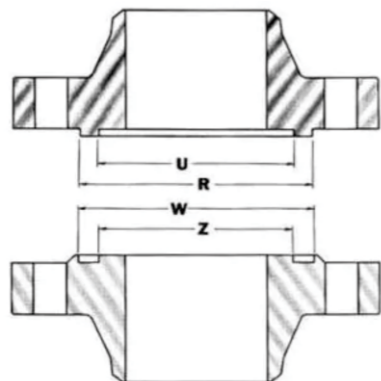

Large-Tongue-and-Groove

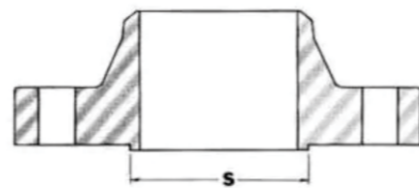

Small-Male-and-Female

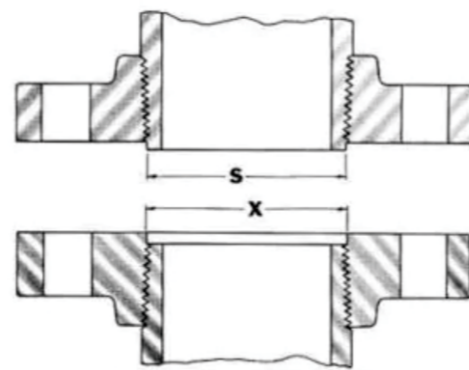

Small-Male-and-Female on-end-of-pipe

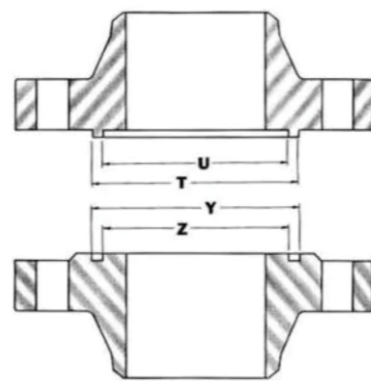

Small-Tongue-and-Groove

▶ Alternate Flange Facings For 150 | 300 | 400 | 600 | 900 | 1500 | 2500 LB FLANGES

Nominal Size (in.)	RF, LJ, Large Male and Large Tongue	Small Male (3)	Small Tongue	ID of Large and Small Tongue	Large Female and Large Groove	Small Female (3)	Small Groove	ID of Large and Small Groove	Raised Face 150 and 300 Pound Standards (2)	RF, Large and Small Male and Tongue 400, 600, 900, 1500, & 2500 lb. Standards (2)	Depth of Groove or Female
	R	S	T	U	W	X	Y	Z			
1/2	1.38	0.72	1.38	1	1.44	0.78	1.44	0.94	0.06	0.25	0.19
3/4	1.69	0.94	1.69	1.31	1.75	1	1.75	1.25	0.06	0.25	0.19
1	2	1.19	1.88	1.5	2.06	1.25	1.94	1.44	0.06	0.25	0.19
1 1/4	2.5	1.5	2.25	1.88	2.56	1.56	2.31	1.81	0.06	0.25	0.19
1 1/2	2.88	1.75	2.5	2.12	2.94	1.81	2.56	2.06	0.06	0.25	0.19
2	3.62	2.25	3.25	2.88	3.69	2.31	3.31	2.81	0.06	0.25	0.19
2 1/2	4.12	2.69	3.75	3.38	4.19	2.75	3.81	3.31	0.06	0.25	0.19
3	5	3.31	4.62	4.25	5.06	3.38	4.69	4.19	0.06	0.25	0.19
3 1/2	5.5	3.81	5.12	4.75	5.56	3.88	5.19	4.69	0.06	0.25	0.19
4	6.19	4.31	5.69	5.19	6.25	4.38	5.75	5.12	0.06	0.25	0.19
5	7.31	5.38	6.81	6.31	7.38	5.44	6.88	6.25	0.06	0.25	0.19
6	8.5	6.38	8	7.5	8.56	6.44	8.06	7.44	0.06	0.25	0.19
8	10.62	8.38	10	9.38	10.69	8.44	10.06	9.31	0.06	0.25	0.19
10	12.75	10.5	12	11.25	12.81	10.56	12.06	11.19	0.06	0.25	0.19
12	15	12.5	14.25	13.5	15.06	12.56	14.31	13.44	0.06	0.25	0.19
14	16.25	13.75	15.5	14.75	16.31	13.81	15.56	14.69	0.06	0.25	0.19
16	18.5	15.75	17.62	16.75	18.56	15.81	17.69	16.69	0.06	0.25	0.19
18	21	17.75	20.12	19.25	21.06	17.81	20.19	19.19	0.06	0.25	0.19
20	23	19.75	22	21	23.06	19.81	22.06	20.94	0.06	0.25	0.19
24	27.25	23.75	26.25	25.25	27.31	23.81	26.31	25.19	0.06	0.25	0.19

(1) Regular facing for 150 and 300 lb. steel flanged fittings and flange standards is a 1/16" raised face included in the minimum flange thickness. A 1/16" raised face is also permitted on the 400, 600, 900, 1500, and 2500 lb. flange standards, but it must be added to the minimum flange thickness

(2) Regular facing for 400, 600, 900, 1500, and 2500 lb. flange standards is a 1/4" raised face not included in minimum flange thickness dimensions

(3) Dimensions shown are consistent with specifications predating the 1990's. Alternate face connections are typically supplied to meet older designs. Please specify if your requirements dictate otherwise

